



— 中国·常州 —

龙湖干燥

LONGHU DRYING



— 中国·常州 —

常州市龙湖干燥工程有限公司
CHANGZHOU SHI LONGHU DRYING ENGINEERING CO.,LTD.

地址：江苏省常州市焦溪镇工业园
联系人：顾志栋
手机：13801509290
电话：0519-81191278
传真：0519-88909278
网址：www.longhudry.com
邮箱：2008@longhudry.com

Address : JiaoXi Town ChangZhou City JiangSu Province
Contact : ZhiDong Gu
Mob:13801509290
Tel : +86-519-81191278
Fax : +86-519-88909278
Http : //www.longhudry.com
E-mail : 2008@longhudry.com

注：1. 本公司对本样本所涉及内容拥有版权，未经授权，不得翻印，违者必究；
2. 本公司对本样本内容已仔细校对，对于印刷错误不承担责任；
3. 本公司保留对产品改进的权利，恕不另行通知。

1. Company owns the copyright of the contents of this catalogue, any copy without authorization should be prosecuted.
2. The contents of this company has been double checked, but company will bear any responsibility if there's any mistake during printing.
3. Company reserves the right to amend the contents of this catalogue without notice.



特别警告：对于易燃易爆物的干燥，未经本公司许可，本公司不承担相关责任。

Warning: For drying flammable or explosive materials, our company will not bear any responsibility if without our special agreement.

常州市龙湖干燥工程有限公司
CHANGZHOU SHI LONGHU DRYING ENGINEERING CO.,LTD.

公司简介

COMPANY PROFILE 公司简介
COMPANY PROFILE COMPANY PROFILE
Company profile COMPANY PROFILE

常州市龙湖干燥工程有限公司位于全国百强市风景秀丽、交通便利的江南名镇——常州焦溪。东连上海，南临无锡、苏州，北靠长江，地处“黄金通道”之称的沪宁高速公路旁，系全国干燥设备生产基地，主要生产干燥设备，混合设备、制粒设备，除尘设备等。

本公司成立以来，长期与一些科技院校合作，并吸收国内外的先进技术与经验，在干燥设备的开发、研究中，不断地创新与改造，设计制造了一系列工艺先进且节能的产品，并根据市场的需要，开发制造了十几种专用的干燥设备，如CPE、酒糟、白炭黑等物料的干燥设备。

本公司历来以严谨的科学态度、精湛的技术、按GMP的标准生产出一流的产品，并以优良的服务、合理的价格，竭诚为全国医药、化工、食品、轻工等行业的企业服务。

本公司以市场为导向、科学为依托，并充分发挥各种科技人员的作用，不断更新开发新产品，并以严谨的企业管理、科学的检测手段、优良的售后服务取信于各新老客户。

让我们携手共进，共创辉煌！

ChangZhou LongHu drying engineering CO., LTD is located in the national top city beautiful scenery, convenient transportation of jiangnan town - changzhou jiaoxi town. East by Shanghai, wuxi, suzhou in the south, north of the Yangtze river, is located in the "golden channel," said the huning highway, fasten the drying equipment production base, the main production of drying equipment, mixing equipment, granulating equipment, dust removal equipment, etc.

The company since its inception, the long-term cooperation with some of the colleges and universities of science and technology, and absorb domestic and foreign advanced technology and experience, in the development of drying equipment, research, constant innovation and transformation, the design and manufacture a series of energy-saving products, advanced technology and to meet the needs of the market, the development created a dozen special drying equipment, such as CPE, lees, white carbon black material drying equipment.

The company has always been to the rigorous scientific attitude, superb technology, according to GMP standards to produce first-class products, and with excellent service, reasonable price, wholeheartedly for the pharmaceutical, chemical, food, light industry and other industry enterprise service.

The company, which is based on the market as the guidance, scientific, and give full play to the role of the various kinds of scientific and technological personnel, and constantly updated to develop new products, and the strict enterprise management, scientific testing means and excellent after-sales service win the trust from various old and new customers.

Let us work hand in hand to create brilliant!

先进技术 完善工艺 放心产品

SCALE PRODUCTION QUALITY ASSURANCE

规模生产 品质保证

公司坚持以科技为依托，不断吸收国内外先进机械加工及设计经验，大胆创新研制，引进高素质人才，强化企业内部管理，以灵活的经营机制积极参与市场竞争，以质量求生存、以科技求发展，以领先的制造技术、优良的设备质量、一流的售后服务，赢得了广大海内外客户的支持和信赖。

Company has the rich production experience in the field of drying and talent, technology, management advantages, the company brings together industry has a high-quality professional and technical staff, to provide users with complete sets of engineering design and manufacture, installation, debugging and technical operation training.



C CONTENT

干燥设备专业制造商
Professional Manufacturer of Drying Equipment

产品目录

造最优的产品 树最佳的信誉
Manufacturing best products, and building best image

干燥系列 Drying Series

- 01 LPG系列高速离心喷雾干燥机 LPG Series High-Speed Centrifugal Spray Dryer
- 03 YPG系列压力式喷雾造粒干燥机 YPG Series Pressure Spray Granulation Dryer
- 05 ZLPG系列中药浸膏专用喷雾干燥机 ZLPG Series Spray Dryer For Chinese Raditopnal Medicine Extract
- 07 GXP系列闭路循环喷雾干燥机 GXP Series Sealed Circulation Spray Dryer
- 08 NLG系列内加热流化床干燥机 NLG Series Inner Heating Fluid Bed Dryer
- 09 ZLG系列振动流化床干燥机 ZLG Series Rectilinear Vibrating-Fluidizing Dryer
- 11 XSG系列旋转闪蒸干燥机 XSG Series Revolving Flash Vaporization Dryer
- 13 GFG系列高效沸腾干燥机 GFG Series High-Efficiency Fluidizing Dryer
- 14 FG系列立式沸腾干燥机 FG Series Vertical Fluidized Dryer
- 15 XF系列沸腾干燥机 XF Series Fluidizing Dryer
- 17 QG/FG系列气流干燥机 QG/FG Series Air Steam Dryer
- 19 HZG系列回转滚筒干燥机 HZG Series Rotation Drum Dryer
- 21 HG系列(单鼓、双鼓)滚筒刮板干燥机 HG Series (Single/Double Cylinder)Rotary Cylinder Dryer
- 23 PLG系列盘式连续干燥机 PLG Series Continual Plate Dryer
- 27 KJG系列空心桨叶干燥机 KJG Series Hollow Blade Dryer
- 29 ZPG系列真空耙式干燥机 ZPG Series Vacuum Harrow Dryer
- 31 YZG/FZG系列(圆形/方形)真空干燥机 YZG/FZG Series (Round/Square)Vacuum Dryer
- 33 SZG系列双锥回转真空干燥机 SZG Series Conical Vacuum Dryer
- 35 CT-C系列热风循环烘箱 CT-C Series Hot Air Circulating Drying Oven
- 38 SG系列隧道式热风烘箱 SG series Tunnel Type Hot Air Oven
- 39 DW系列单层带式干燥机 DW Series Single-layer Mesh-Belt Dryer
- 41 DW系列多层带式干燥机 DW Series Multi-layer Mesh-Belt Dryer
- 43 DWT系列脱水蔬菜干燥机 DWT Series Dryer For Vegetable Dehydration

制粒系列 Granulator Series

- 45 FL系列沸腾制粒干燥机 FL Series Fluidized Granulator
- 47 FLP系列多功能制粒包衣机 FLP Series Multi-Function Granulator and Coater
- 49 DH系列干法辊压制粒机 DH Series Dry Granulating Set

混合系列 Mixer Series

- 51 GHL系列高效湿法混合制粒机 GHL Series High Speed Mixing Granulator
- 53 KZL系列快速整粒机 KZL Series High-Speed Grinding Granulator
- 53 QZL球形抛丸机 QZL Spherical shot blasting
- 54 ZLB旋转式制粒机 ZLB Extrude Granulator
- 54 YK160系列摇摆式制粒机 Model YK160 Swaying Granulator
- 55 EYH系列摇摆式(二维)混合机 EYE Series Two Dimensional Mixer
- 56 SYH系列摇摆式(三维)混合机 SYH Series Three Dimensional Mixer
- 57 DSH系列锥形双螺杆螺旋混合机 DSH Series Double-screw Conical Mixer
- 58 DSH系列锥形螺杆螺带混合机 DSH Series Screw Conical Mixer
- 59 VHJ型系列混合机 VHJ Series Mixers
- 60 FZH系列方锥型混合机 FZH Series Squarecone Mixer
- 61 SZH系列双锥混合机 SZH Series Double Conical Mixer
- 62 CH系列槽形混合机 CH Series Notch Shape Mixer
- 62 GHJ系列立式高速高效混合机 GHJ Series Of Vertical Speed, High Efficiency Mixer
- 63 WZ系列无重力混合机 WZ Series Zero-Gravity Mixer
- 64 WLDH系列卧式螺带混合机 WLDH Series Horizontal Ribbon Mixer
- 64 LDH系列犁刀混合机 LDH Series Coulter Mixing Machine

粉碎系列 Grinder Series

- 65 30B系列高效粉碎机(组) 30B Series High Effect Grinding Machine(set)
- 65 WF-30B 中草药粉碎机组 WF-30B China Herb High Speed Grinder
- 66 C系列万能粉碎机 C Series Universal Grinder
- 66 CSJ粗粉碎机 CSJ Series Date And Efficient Coarse Grinder
- 67 GFS系列高效粉碎机 GFS Series High Efficient Grinding Machine
- 67 WFJ系列粉碎机 WFJ Series Fine Grinder

辅助系列 Auxiliary Series

- 68 FS系列方形振动筛 FS Series Square Vibrating Sieve
- 68 ZS系列圆形振动筛 ZS Series Vibrating Sieve
- 69 JRF系列燃煤热风炉 JRF Series Coal Combustion Hot Air Furnace
- 70 RLY系列燃油、RQY燃气热风炉 RLY/RQY Series Oil Fuel,Gas Fuel Hot Air Furnace
- 71 MC-II系列方形脉冲布袋除尘器 MC-II Series Plus Dust Filter With Cloth Bag
- 72 ZSL-III系列真空上料机 ZSL-III Serial Vacuum Feeder
- 73 JH系列酒精回收塔 JH Series Alcohol Recovery Tower

概述 Descriptions

喷雾干燥是液体工艺成形和干燥工业中应用最广泛的工艺。最适用于从溶液、乳液、悬浮液和糊状液体原料中生成粉状、颗粒状固体产品。因此，当成品的颗粒大小分布、残留水份含量、堆积密度和颗粒形状必须符合精确的标准时，喷雾干燥是一道十分理想的工艺。

Spray drying is the technology most widely used in the liquid technology shaping and in the drying industry. The drying technology is most suitable for producing solid powder or particle products from liquid materials, such as: solution, emulsion, suspension and pumpable paste states. For this reason, when the particle size and distribution of the final products, residual water contents, mass density and the particle shape must meet the precise standard, spray drying is one of the most desired technologies.

原理 Principle

空气经过过滤和加热，进入干燥器顶部空气分配器，热空气呈螺旋状均匀地进入干燥室。料液经塔体顶部的高速离心雾化器，（旋转）喷雾成极细微的雾状液珠，与热空气并流接触，在极短的时间内可干燥为成品。成品连续地由干燥塔底部和旋风分离器中输出，废气由风机排空。

After the air been filtered and heated the air enters into the air distributor on the top of the dryer. The hot air enters into the drying room in the spiral form and uniformly. Passing through the high-speed centrifugal sprayer on the top of the tower, the material liquid will rotate and be sprayed into the extremely fine mist liquid beads. Through the very short time of contacting the heat air, the materials can be dried into the final products. The final products will be discharged continuously from the bottom of the drying tower and from the cyclones. The waste gas will be discharged from blower.

工艺流程 Technological process

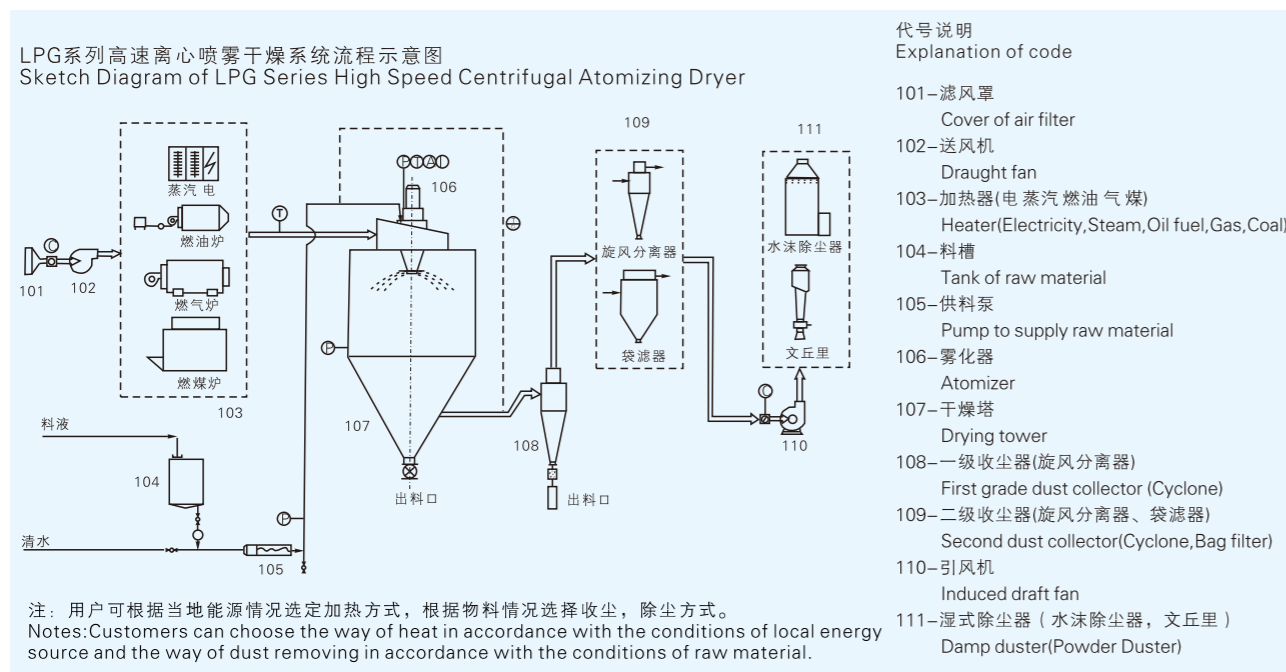

特点 Features

干燥速度快，料液经雾化后，表面积大大增加，在热风气流中，瞬间就可蒸发95%-98%的水份，完成干燥时间仅需数秒钟，特别适用于热敏性物料的干燥。

产品具有良好的均匀度、流动性和溶解性、产品纯度高、质量好。

生产过程简化，操作控制方便。对于湿含量40-60%(特殊物料可达90%)的液体能一次干燥成粉粒产品，干燥后不需粉碎和筛选，减少生产工序，提高产品纯度。对产品粒径、松密度、水份，在一定范围内可通过改变操作条件进行调整，控制和管理都很方便。

The drying speed is high when the material liquid is atomized, the surface area of the material will increase greatly. In the hot-air flow, 95%-98% of water can be evaporated at a moment. The time of completing the drying is only several seconds. This is especially suitable for drying the heat sensitive materials.

Its final products own the good uniformity, flow ability & solubility. And the final products are high in purity and good in quality.

The production procedures are simple and the operation and control are easy. The liquid with moisture contents of 40-60% (for special materials, the contents might be up to 90%) can be dried into the powder or particle products once a time. After the drying process, there is no need for smashing and sorting, so as to reduce the operation procedures in the production and to enhance the product purity. The product particle diameters, looseness and water contents can be adjusted through changing the operation condition within a certain range. It is very convenient to carry out control and management.

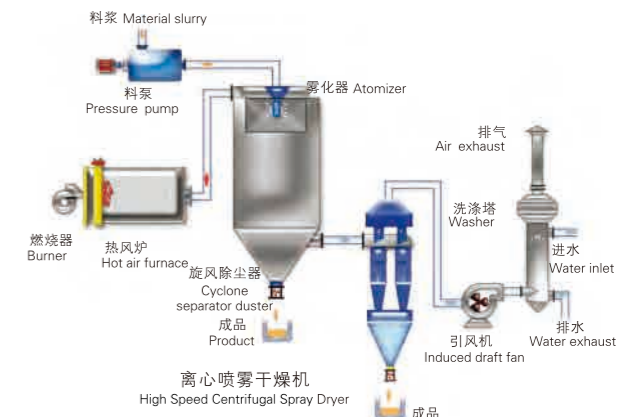

技术参数 Technical parameters

项目 item	参数parameter	LPG					
		5	25	50	100	150	200-2000
入口温度 inlet temperature °C		140-350 自控 automatically controlled					
出口温度 outlet temperature °C		~80-90					
水份最大蒸发量kg/h Max. water evaporation capacity		5	25	50	100	150	200-2000
离心喷雾头转动形式 centrifugal spraying nozzle transmission mode		压缩空气传动 compressed air transmission	机械传动 mechanical transmission				
转速(r.p.m) rotation speed		25000	18000	18000	18000	15000	8000-15000
喷雾盘直径(mm) spraying desc diameter		50	100	120	140	150	180-340
热源 heat supply		电 Electricity	电+蒸汽 electricity+steam	电+蒸汽、燃油、煤气 electricity+steam, fuel oil and gas			由用户自己解决 settled by users themselves
电加热最大功率kW Max electric heating power		9	36	63	81	99	
长度×宽度×高度(m) overall dimensions		1.8×0.93×2.2	3×2.7×4.26	3.7×3.2×5.1	4.6×4.2×6	5.5×4.5×7	根据具体情况确定 depends on the concrete conditions
干粉回收率% dried powder collecting		≥95	≥95	≥95	≥95	≥95	≥95

注：部分参数设计时视不同物料有所调整，以设计为准。

► 应用 Applications

食品、医药、化工、染化、陶瓷、生化、农药、塑料等适用具有相应流动性的液体。

It is suitable for liquid of foodstuff, pharmaceutical, chemical industry, dyestuff, ceramics, agrochemicals, plastic and so on.

► 工艺流程 Technological process

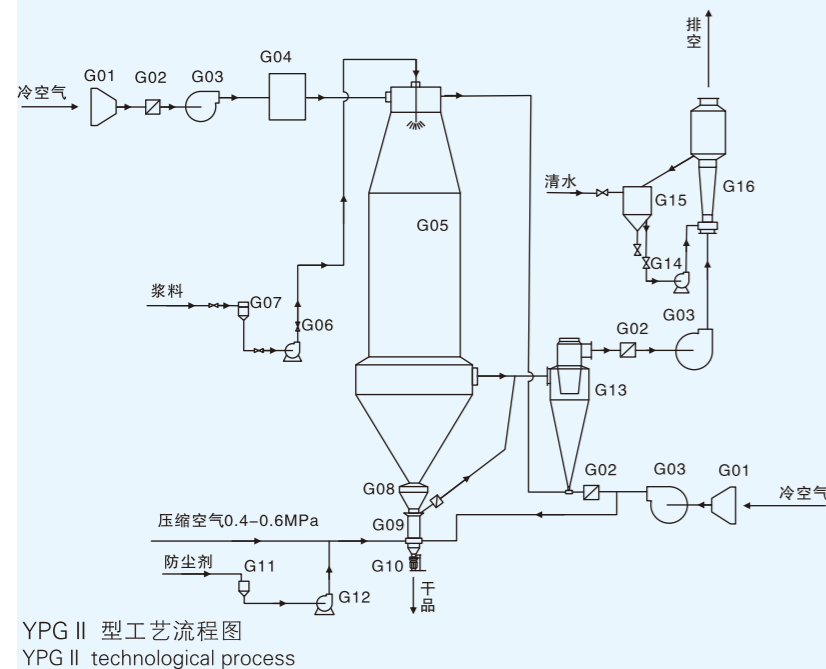
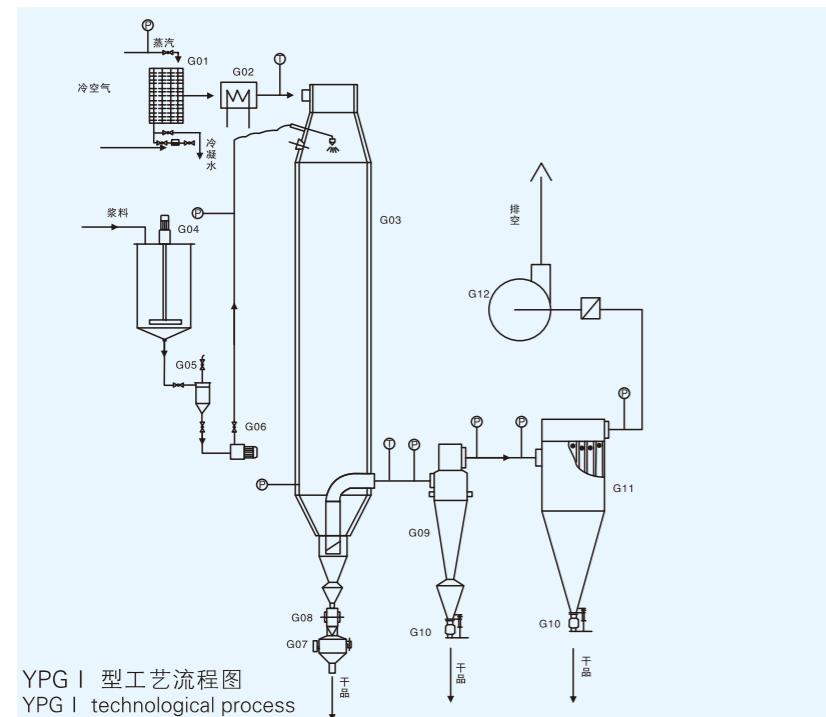

► 概述 Descriptions

压力式喷雾干燥造粒机是采用压力式雾化器借助隔膜泵的压力将溶液或浆状的物料雾化成细微液滴，使表面积显著增大，经与热风进行充分热交换得以快速干燥(十几秒至几十秒)，从而得到粉体或细小颗粒产品的设备。

The liquid or paste raw material is sprayed into minuty liquid drop by pressed sprayer draw assistance from pressure of diaphragm pump, and quickly drying through short heat exchange.(10sec.) at last, the powder or small granule is obtained.

► 特点 Features

- ◇ 干燥速度快，特别适用于热敏性物料：
- ◇ 所得产品为球状颗粒，粒度均匀，流动性、溶解性好，产品纯度高，质量好；
- ◇ 使用范围广，可进行热风干燥、造粒、也可以进行冷却造粒、喷雾结晶、喷雾反应等。
- ◇ 可配备细粉回送，再湿附聚系统，满足用户对物料粒径的要求。
- ◇ 操作简单稳定，控制方便，容易实现自动化作业，产品粒径、松密度、水份在一定范围内可以调节。
- ◇ The dry speed is fast and suitable for drying thermal sensitivity material particularly.
- ◇ The finished product is ball granule with uniform size. Its fluidity and solubility are good. The purity of product is high and its quaity is good.
- ◇ It applied scope is wide. According to the characteristics of raw material, it can use hot air to dry and can also use cool air to granulate. It has strong adaptability to raw materials.
- ◇ Its operation is simple and stable and its control is simple and convenient and is easy to realize automatic operation.
- ◇ The product particle diameters, looseness and water contents can be adjusted through changing the operation condition within a certain range.

► 技术参数 Technical parameters

型号 spec	单位unit	50	100	150	200	300	500	1000
水份蒸发量 water evaporation capacity	Kg/h	50	100	150	200	300	500	1000
外形尺寸 overall dimension (φ × H)	mm	1600 × 8900	2000 × 11500	2400 × 13500	2800 × 14800	3200 × 15400	3800 × 18800	4600 × 22500
高压泵压力 high-pressure pump pressure	Mpa	2-10						
功率 power	kW	8.5	14	22	24	30	82	30
进风温度 inlet air temperature	℃	300-350						
产品含水量 product water contents	%	< 5(可达0.5) less than 5 percent, and 5 percent can be achieved.						
物料回收 material restoration	%	> 97						

注：部分参数设计时视不同物料有所调整，以设计为准。



概述 Descriptions

中药浸膏专用喷雾干燥机是吸收国外技术开发的适用于熔点低、含糖高的中药产品的干燥机械，并具有不粘壁、物料不焦化、不易吸潮等特点。该装置根据干燥产品的特点和性质确定喷雾干燥的工艺条件，自动化程度高，操作方便，符合GMP要求，该装置的成功开发，解决了多年来许多熔点低、含糖高的中药产品不能用喷雾干燥的技术难点，也是对喷雾干燥在中药制药中的应用技术研究的新发展。

Traditional Chinese medicine medicinal extract special-purpose to spray desiccator to absorb to suitable for point low, high in candy content traditional Chinese medicine dry machinery of product foreign technological development, is it glue wall, supplies coking, difficult to inhale such characteristics as the tide, etc. to have. This device confirms and sprays the dry process conditions according to characteristic and nature of the dry products, the automatic degree is high, easy to operate, accord with GMP demand, the success development of this device, solving low traditional Chinese medicine products high in candy content of wanting a lot of to melt in year more can't use and spray the dry technological difficult point, it is a new development of dry application technical research in traditional Chinese medicine pharmacy to spraying too.

特点 Features

- ◇塔体具有冷风夹套；
- ◇塔体上装有自动振打装置；
- ◇塔体、管路配有快开清洗孔及排污孔；
- ◇自动控制恒温加料罐；
- ◇手工高压洗塔随机附件；
- ◇与物料接触的部分采用不锈钢材料制作；（或全不锈钢制造）
- ◇物料收集采用两级旋风除尘装置，或一级旋风除尘器和湿式除尘器；
- ◇进风温度实现自动控制及连续装置。
- ◇配有气扫装置。

- ◇Tower body has jacket of air.
- ◇Tower body is equipped with automatic vibration and beating device;
- ◇Tower body and pipe line have cleaning hole and sewage discharge hole that can open quickly.
- ◇Thermostat ending tank;
- ◇Accompanied parts of high pressure washing tower;
- ◇The parts that can contact with raw material are made of stainless steel fully;
- ◇The collecting fo raw material adapts two gradecyclone duster or one-grade cyclone duster and one-grade damp duster ;
- ◇The temperature of inlet air can be controlled automatically and continuously;
- ◇Equipped with air sweeping device.



扫壁系统
Sweeping system



控制系统
Control System



冷冻除湿冷却系统
Desiccant cooling system freezing

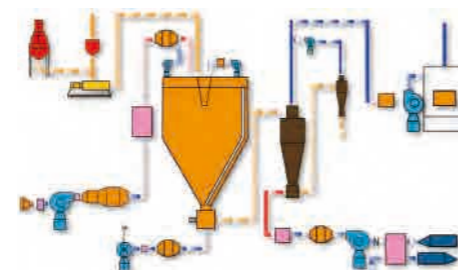

系统流程图
System flow chart

原理 Principle

中药浸膏高速离心式喷雾装置是离心式喷雾干燥技术在特定物料干燥中的应用，也是利用高速离心式雾化器使物料分散成细，与热空气充分接触，完成瞬间干燥，形成粉状成品的干燥装置。该干燥设备是专门用来解决中药浸膏和植物提取液的喷雾干燥机，它有效地解决了原LPG高速喷雾干燥机在中药浸膏干燥中出现的粘壁、焦化、收粉率低、产量低等问题。

Application in dry technology is dry in the specific supplies that the device sprays centrifugally that the medicinal extract high speed of traditional Chinese medicine sprays centrifugally, utilize the centrifugal atomizer of high speed to make the supplies dispersed thinly, fully keep in touch with the hot air too, it is dry to finish the twinkling of an eye, form the dry device of the powdery finished product. Dry equipment this is it solve traditional Chinese medicine medicinal extract and plant spraying desiccator to draw liquid to used for specially, it solve original LPG spray whom desiccator appear until traditional Chinese medicine medicinal extract dry glue wall, coking, charge powder rate low, output low grade problem at a high speed effectively.

结构示意图 Sketch of structure

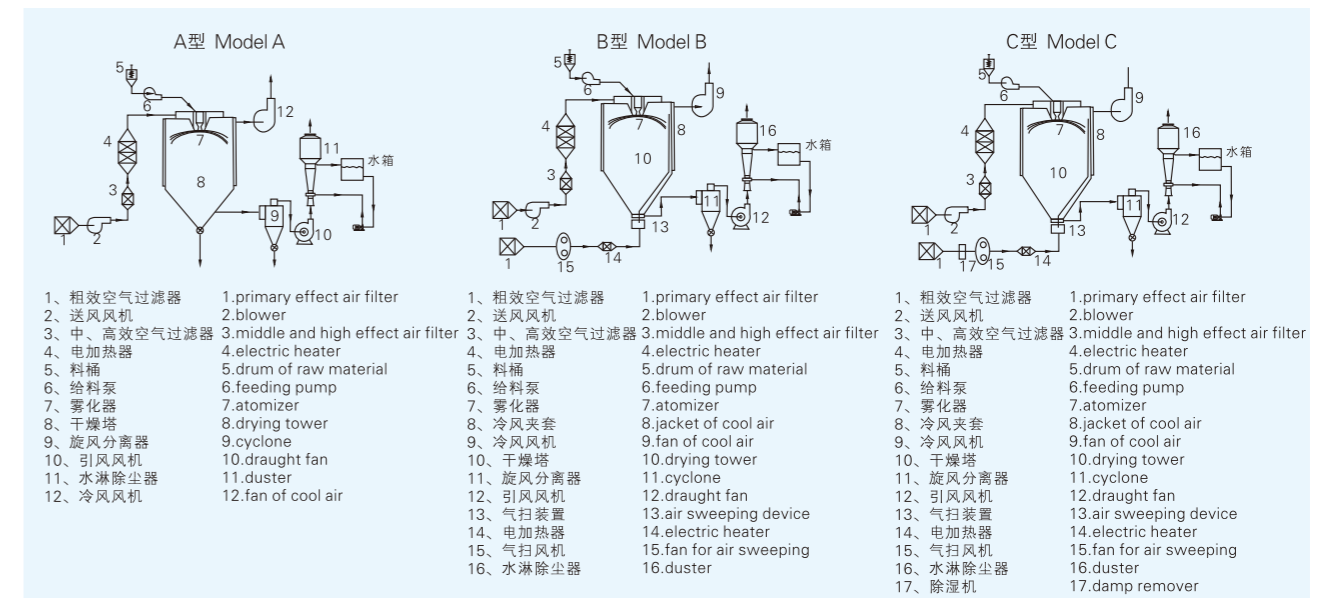

技术参数 Technical parameters

型号spec	ZLPG-5	ZLPG-10	ZLPG-25	ZLPG-50	ZLPG-80	ZLPG-100	ZLPG-150	ZLPG-200	ZLPG-300	
水份蒸发量 evaporation capacity(kg/h)	5	10	25	50	80	100	150	200	300	
料液处理量 process amount of material liquid(kg/h)	6-7	12-14	25-34	50-68	80-108	100-135	150-203	200-270	300-406	
成品含量 output of finished product(kg/h)	1-2	2-4	4.8-7.2	9.2-14	14.8-22.4	18.4-28	24-42	36.8-56.4	55-85	
湿物料含固量 solid content of material liquid(%)	18-25									
成品含水率 moisture content of finished product(%)	3-5									
电功率 electric power(kw)	36	45	63	99	132	153	204	246	330	
加热源 heat source	蒸汽加热 Steam plus electricity									
产品捕集方式及效率 collecting method of product and its efficiency	两级旋风除尘器或一级旋风除尘器及一级湿式除尘器≥95%									
自控仪表 automatic control meters and instruments	热风温度及排风温度指标，自动调节温控仪 indicator of temperature of air and humidity of air exhaust									
进风温度 temperature of air inlet(°C)	150-200									
出风温度 temperature of air outlet(°C)	80-100									
外形尺寸 overall diimensions(mm)	长L	5000	5500	7000	8000	9800	11000	12200	14100	15000
	宽W	3000	3500	4000	5000	5700	6200	7000	7800	9000
	高H	4500	4600	5200	6500	7600	8100	10000	9850	11100



结构示意图 Sketch of structure

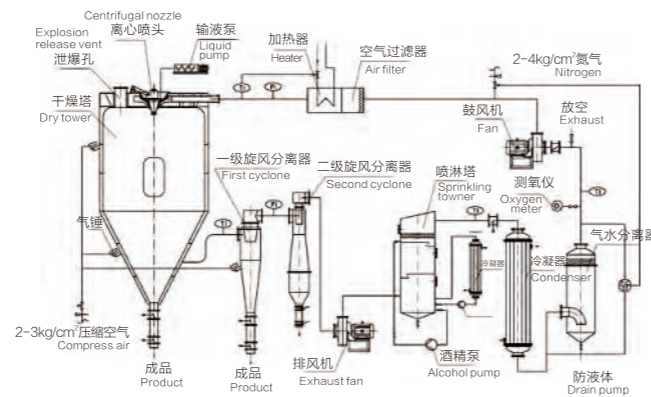

原理 Principle

闭式循环喷雾干燥系统是在密闭的环境下工作，干燥介质为惰性气体，一般为N₂，适用于有机溶剂的物料干燥有毒气的物料或干燥过程中易发生氧化的物料的干燥；该系统采用惰性气体作为循环气体，对干燥的物料具有保护作用，循环气体经历载湿、去湿的过程，介质可重复使用；氮气经加热器加热后进入干燥塔，液体物料经螺杆泵输送至离心喷头处，液体被高速循环的雾化器雾化成液滴，在干燥塔内完成热质交换过程，被干燥后的粉状物料从塔底排出，被蒸发的有机溶剂气体在风机负压的压力下，把夹在气体中的粉尘经旋风分离器、喷淋塔除尘后饱和的有机溶剂气体经冷凝器冷凝成液体排出冷凝器，不凝性气体介质连续加热后作为干燥载体在系统内重新循环使用。而常规的普通的离心喷雾干燥是通过不断的送、排风达到排湿的目的，这也是防爆型闭式离心喷雾干燥设备与普通离心喷雾干燥设备的一个明显区别；干燥系统内干燥介质为N₂，内部为正压操作，保持一定的正值，如果内部压力下降，由压力变送器来自自动控制N₂进量，保证系统压力平衡。

Seal circulation spray drying system works in a seal circumstance. The drying gas is usually inert gas, such as N₂. It's applicable for drying material with organic solvent, toxic gas and the material easy to be oxidized. adopt inert gas as circulation gas, so to protect the material to be dried. The inert gas circulates after dehumidification process. N₂ is heated and then enters into drying tower. Liquid material is conveyed to centrifugal nozzle by screw pump, and then it's atomized into the liquid mist by the atomizer, the heat transferring process is finished in the drying tower. The dry product is discharged at the bottom of tower, the evaporated organic solvent is sucked by the vacuum generated by the fan. Power or solid material will be separated in the cyclone and sprinkling tower. The saturated organic gas is drained out after it's condensed in the condenser. The gas not condensed recycles in the system after it's heated continuously. Ordinary normal centrifugal spray drying process is realized by air conveying and exhausting process. This is the obvious difference between explosion proof type sealed circulation centrifugal spray dryer and ordinary centrifugal spray dryer. The drying media in drying system is N₂, the interior is under positive pressure. To keep positive pressure stable, the pressure transmitter controls the inlet amount of N₂ automatically.

技术参数 Technical parameters

干粉回收率 dried powder collecting	≥95%
产品残余溶剂 remanent disolvent	≤2%
系统含氧量 oxygen contents	≤500PPM
电器防爆 explosion-proof of electric components	EXDIIBT4
设备系统 system condition	正压状态 positive pressure

概述 Descriptions

内加热流化床干燥机是在常规流化床干燥和间接加热式干燥基础上发展起来的一种新型干燥技术。将热交换器沉浸在流态化干燥物料中，物料脱水所需热量分别由管式热交换器和流化用热空气提供，可以较小的风量满足物料流化干燥的要求。由于大部分热量是由内置热交换器提供，热空气主要是作为保证正常流态化的动力媒体，因此比常规流化床干燥机所需热空气量大大降低，电耗及尾气热损失大幅度减少。

Inner heated fluid bed dryer is developed based on normal fluid bed dryer and indirect heated dryer. Immerse the heat exchanger in the material that is fluidized and dried. The heat required for dewatering is provided by tube heat exchanger and fluidizing hot air. The air velocity required for to dry the material is less. The main heat is provided by the heat exchanger inside, the hot air is mainly for fluidization of material, so the hot air velocity required is much less compare to normal fluid bed dryer, power consumption and heat lost with the tail gas are sharply reduced.



适用物料 Materials

适用物料：氯化铵、硝酸铵、氯化钙、甲酸钙、葡萄糖钙、硫酸钙、纤维素衍生物、磷酸二铵、磷酸二钙、成粒肥料、对苯二酚、硫酸铁、乙烯、丙烯、聚苯乙烯、碳酸钾、氯化钾、硝酸钾、磷酸钾、酒石酸钠钾、硫酸钠、聚氯乙烯、碳酸氢钠、溴化钠、甲酸钠、过硼酸钠、硫酸钠、酒石酸、对苯二甲酸、尿素、维生素。硫酸钡、硫酸镁、硫酸锌、硫酸铝、硫酸镍、硫酸铵、食盐、氟化钠、钛白粉、溴化钾、溴化铵、碳酸钠、碱式碳酸镍、碱式碳酸锌、碱式碳酸铬、碳酸钙、偏硅酸钠、红矾钠、醋酸钾、苯钾酸钠、丙烯酸酯单体、聚丙烯酰胺、尼成1010、聚丙烯树脂、涤纶切片、聚四氟乙烯、酰胺树脂、土霉素、四环素、酞酐素、腐植酸、腐植酸钠、赖氨酸。

特点 Features

- ◇ 节能高效，运行成本低。
- ◇ 干燥空气量小，系统电耗低。
- ◇ 干燥强度高，设备体积小，系统占地面积小。
- ◇ 操作弹性大，系统操作稳定。
- ◇ 特殊布风板，可防止漏料并有利于大颗粒物料的排出。
- ◇ 采用两级除尘，可达到环保排放要求。

- ◇ Energy saving, low running cost.
- ◇ The amount of drying air is less; the power consumption is low.
- ◇ The drying capacity is high; the volume of equipment is small; the area occupied is less.
- ◇ The operation flexibility is high; the operation of system is steady.
- ◇ Adopt special air distributing board, so to avoid leakage of material, and it's good for discharging material of big particles.
- ◇ Adopt two grades of dust filter, so to meet exhaust requirements of environment.

技术参数 Technical parameters

型号 spec	流化面积(m ²) fluidized area	装机功率(Kw) power	蒸汽压力(Mpa) steam pressure	蒸汽消耗(Kg/h) steam consumption	进口风温℃ Tem.of inlet air	外形尺寸(L×W×H)mm overall diemensions	占地面积(m ²) occupying area
NLG2.0	2	50	0.2-1.0	400-1000	100-300	3000×1300×4500	45
NLG2.5	2.5	65	0.2-1.0	600-1200	100-300	3500×1300×4500	55
NLG3.0	3	85	0.2-1.0	1400-2200	100-300	3600×1400×4500	65
NLG3.5	3.5	95	0.2-1.0	1000-2000	100-300	4000×1500×4500	80
NLG4.0	4.0	110	0.2-1.0	1200-2000	100-300	4600×1600×5000	90
NLG5.5	5.5	130	0.2-1.0	1400-2200	100-300	5000×1650×5000	100
NLG6.0	6	140	0.2-1.0	1600-2800	100-300	6000×1700×5000	110
NLG7.0	7	165	0.2-1.0	1800-3200	100-300	6600×1750×5000	120
NLG8.0	8	170	0.2-1.0	2000-2800	100-300	7500×1800×5000	130
NLG10	10	210	0.2-1.0	2400-3600	100-300	10000×1900×6500	140
NLG15	15	300	0.2-1.0	3200-4400	100-300	15000×1900×6500	200
NLG20	20	320	0.2-1.0	4000-6000	100-300	20000×2000×7000	240

注：部分参数设计时视不同物料有所调整，以设计为准。

概述 Descriptions

ZLG振动流化床干燥机广泛适用于化工、轻工、医药、食品、塑料、粮油、矿渣、制盐、糖等行业的粉料颗粒状物料的干燥、冷却、增湿等作业。作为干燥设备使用时,设备可同时具备干燥和冷却功能,产品可直接包装。大型设备一般采用分体式,以便尽可能减少共振质量,降低能耗。

The drier is suitability in chemical industry, light industry, pharmaceutical, food, plastic, oil, slag, salt, sugar and so on, for drying, cooling and wetting. When used as a drying equipment, the equipment can have drying and cooling functions at the same time, the product can be directly to packing. Large equipment generally adopts the split type, so as to minimize vibration quality, reducing energy consumption.



特点 Features

- ◇ 振动源是采用振动电机驱动, 运转平稳, 维修方便, 噪音低、寿命长。
- ◇ 流态化匀称, 无死空隙和吹穿现象, 可以获得均匀的干燥、冷却制品。
- ◇ 可调性好, 适应面宽。料层厚度和在机内移动速度以及全振幅变更均可实现无级调节。
- ◇ 对物料表面损伤小, 可用于易碎物料的干燥; 物料颗粒不规则时亦不影响工作效果。
- ◇ 采用全封闭式结构, 有效地防止了物料与空气交叉感染, 作业环境清洁。
- ◇ 机械效率与热效率高, 节能效果好, 比一般干燥装置可节能30-60%。

应用 Applications

适用于化工、制药、食品、脱水蔬菜、粮食、矿产等行业的粉状、颗粒状物料的干燥、冷却等作业, 如: 柠檬酸、味精、硼砂、硫酸铵、复合肥、萝卜丝、豆粕、酒糟、种子、矿渣、砂糖等。

- ◇ Adopt vibration motor, it is smooth in running and convenient in maintenance. The noise is low and the service life is long.
- ◇ The state of fluidization is uniform and no dead gaps or broken phenomenon so to have dry, cool product.
- ◇ It is good in adjustment and wide in the field of application. The thickness of raw material and the speed of raw material to be moved inside the machine and the change of vibration range can be stepples.
- ◇ The damage the surface of raw material is small. So it can be used for raw materials that are easily to be broken. If the granule is not normal, the effect of process can not be effected.
- ◇ The structure is fully seal, it is effective to prevent from cross pollution of raw materials and the working environment is clean.
- ◇ The mechanical and heat are high and its effective of energy saving. Compared to ordinal dryer, 30-60% of energy is saved.

It is suitable for the operations of drying, cooling for powder or granule raw materials. They may be citric acid, monosodium glutamate, borax, ammonium sulphate, compound fertilizer, piece of radish, bean, lees, seed, mine residue and sugar, in chemical, pharmaceutical, foodstuff, grain, mine and so on industries.

工艺流程 Technological process

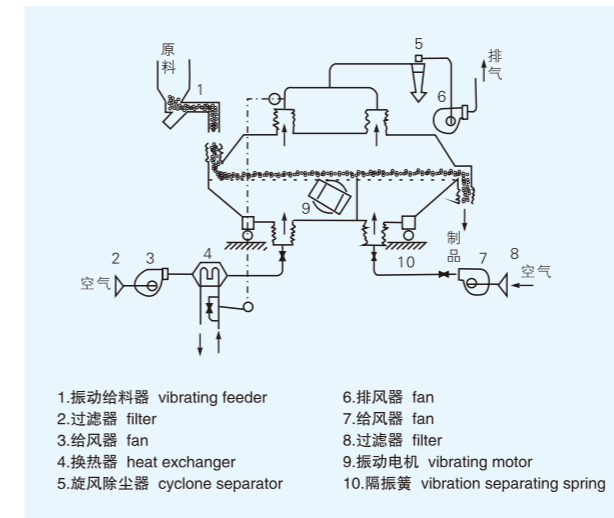

结构示意图 Sketch of structure

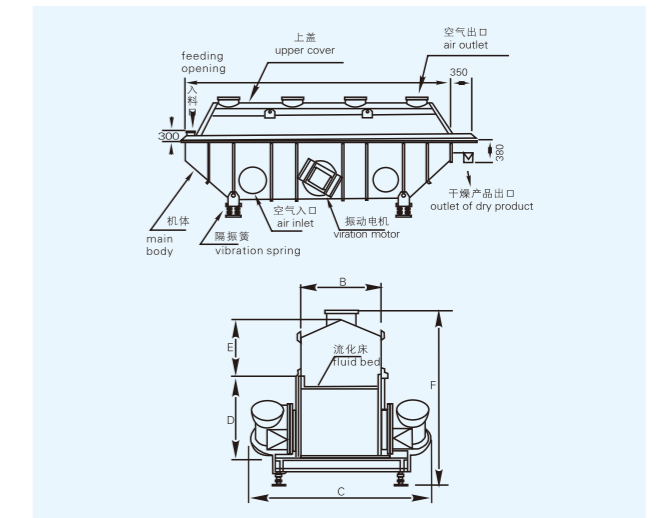

技术参数 Technical parameters

型号 Model	尺寸 Size	A	B	C	D	E	F	重量 weight(Kg)
ZLG-3×0.30		3000	300	1350	900	430	1650	1250
ZLG-4.5×0.30		4500	300	1350	900	430	1650	1560
ZLG-4.5×0.45		4500	450	1550	950	430	1700	1670
ZLG-4.5×0.60		4500	600	1650	950	430	1700	1910
ZLG-6×0.45		6000	450	1650	950	430	1700	2100
ZLG-6×0.60		6000	600	1700	1000	500	1700	2410
ZLG-6×0.75		6000	750	1850	1000	600	1850	2340
ZLG-6×0.9		6000	900	2000	1000	600	1850	3160
ZLG-7.5×0.6		7500	600	1850	1000	600	1850	3200
ZLG-7.5×0.75		7500	750	2000	1000	600	1850	3600
ZLG-7.5×0.9		7500	900	2100	1000	600	1850	4140
ZLG-7.5×1.2		7500	1200	2500	1150	800	2050	5190

机型 Model	流化床面积 Area of fluidized-bed (M ²)	进风温度 Temperature of inlet air (°C)	出风温度 Temperature of outlet (°C)	蒸发水份能力 Capacity to vapor moisture(kg/h)	振动电机 Vibration motor	
					型号 Model	功率 Power kw
ZLG-3×0.30	0.9	70~140	40~70	20~35	ZDS31-6	0.8×2
ZLG-4.5×0.30	1.35			35~50	ZDS31-6	0.8×2
ZLG-4.5×0.45	2.025			50~70	ZDS32-6	1.1×2
ZLG-4.5×0.60	2.7			70~90	ZDS32-6	1.1×2
ZLG-6×0.45	2.7			80~100	ZDS41-6	1.5×2
ZLG-6×0.60	3.6			100~130	ZDS41-6	1.5×2
ZLG-6×0.75	4.5			120~170	ZDS42-6	2.2×2
ZLG-6×0.9	5.4			140~170	ZDS42-6	2.2×2
ZLG-7.5×0.6	4.5			130~150	ZDS42-6	2.2×2
ZLG-7.5×0.75	5.625			150~180	ZDS51-6	3.0×2
ZLG-7.5×0.9	6.75	160~210	ZDS51-6	3.0×2		
ZLG-7.5×1.2	9.0	200~260	ZDS51-6	3.7×2		

概述 Descriptions

旋转闪蒸干燥机是我公司为克服静态干燥低效、高耗而研制开发的新型高效流态化干燥设备。该机在设计过程中充分结合气流干燥等普通流态干燥的特点，扬长避短，使整机具有合理的工艺结构和优越的使用性能，真正实现流态化干燥的低耗、高效目标。

本机应用范围极其广泛，可用于橡塑助剂、农药、颜料、染料精细化工、饲料、医药及部分中间体的脱湿干燥。

The revolving flash vaporization dryer is a new and high, efficiency fluidized drying equipment which is researched and developed for the sake of overcoming the low-efficiency and high-consumed static drying by our company. We have joined the characteristics of ordinary fluidized drying such as air stream drying, in designing process, and have developed advantage and reduced shortcoming with the advantageous usage function. All this really realizes the target of the consuming and high efficiency of the fluidized drying.

The dryer is widely used for drying rubber and plasticizer, agrochemical, pigment, dyestuff, chemical industry, animal feed, medicine and kinds of intermediates.



原理 Principle

热空气由入口管以适宜的喷动速度从干燥机底部进入搅拌粉碎干燥室，对物料产生强烈的剪切、吹浮、旋转作用，于是物料受到离心、剪切、碰撞、摩擦而被除数微粒化，强化了传质传热。在干燥机底部，较大较湿的颗粒团在搅拌器的作用下被机械破碎，湿含量较低、颗粒度较小的颗粒被旋转气流夹带上升，在上升过程中进一步干燥。由于气固两相作旋转流动，固相惯性大于气相，固气两相间的相对速度较大，强化两相间的传质传热，所以该机生产强度高。

The hot air is managed with suitable gushing out the speed of moving and entering and mixing and crushing the dry room from the desiccator bottom by the entry, strong shear, blowing floating, function not rotatory of to supplies produce, then supplies the at odds with the community or the leadership, shear, not collide, rub but dividend particle, have strengthened and spread the quality and conducted heat. In desiccator bottom, heavy wetter particle group broken machinery have under function of agitator, the wet content is lower, the particle and one degree of smaller particles are rotated the air current and carried secretly and risen, it is dry further in the course of rising. Because angry firm two phase rotates to flow, firm looks inertia is greater than the gaseous phase, alternate relative speed two of firm air is relatively large, strengthen two alternate biography qualities and conduct heat, so this machine produces the intensity high.

特点 Features

- ◇ 多种加料装置供选择，加料连续稳定，过程中间不会产生架桥现象。
- ◇ 干燥机底部设置特殊的冷却装置，避免了物料在底部高温区产生变质现象。
- ◇ 特殊的气压密封装置和轴承冷却装置，有效延长传动部分的使用寿命。
- ◇ 特殊的分风装置，降低了设备阻力，并有效提供了干燥器的处理风量。
- ◇ 干燥室装有分级环及旋流片，物料细度和终水份可调。（如碳酸钙终水份可调节器至≤0.1%）
- ◇ 干燥室内周向气速高，物料停留时间短，有效防止物料粘壁及热敏性物料变质现象，达到高效、快速、小设备、大生产。
- ◇ Many kinds of reinforced device is it choose to support, feed in raw material in succession steady, course can produce phenomenon of bridging.
- ◇ Set up the special cooling device in the desiccator bottom, has prevented the supplies from producing the rotten phenomenon in the high-temperature district of the bottom.
- ◇ Special atmospheric pressure seal installation and bearing cool the device, the service life of the running part of effective extension.
- ◇ Special points of wind device, has reduced the obstruction of the equipment, and has offered the wind amount of treatment of the desiccator effectively.
- ◇ Dry room equip with hierarchical ring and swirl slice, supplies detailed degree and end moisture content adjustable. (Such as calcium carbonate end but from regulator to moisture content. 1%)
- ◇ It is high to the angry speed in week in the dry room, the time of staying of supplies is short, prevent the supplies from glueing the temperature sensing closely linked fortifications surround the capital rotten phenomenon of supplies effectively, reach high-efficient, fast, little equipment, great production.



结构示意图 Sketch of structure

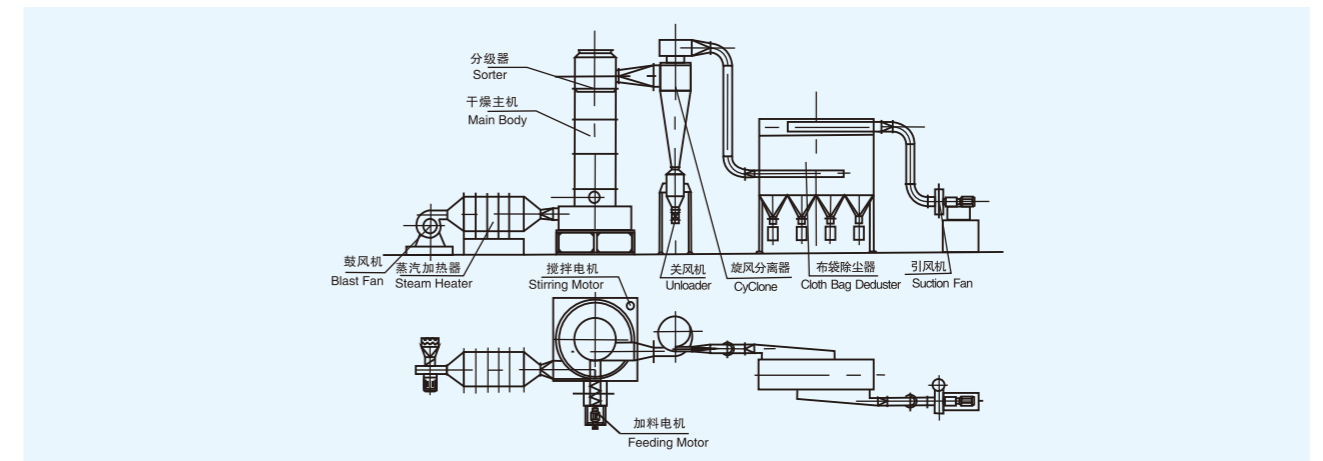

型号 Type	高度 (A) Height	长度 (B) Length	宽度 (C) Width
XSG-4	4600	5500	5000
XSG-6	5500	6550	6000
XSG-8	6000	7100	5600
XSG-10	7100	8200	6700
XSG-12	7500	8900	7000
XSG-14	7800	70580	8500
XSG-16	8500	14500	11000

技术参数 Technical parameters

项目 Items	主机内径(mm) Barrel diameter	处理风量(m³/h) Treatment wind capacity	蒸发水量(kg/h) Water evaporation quantity	最大装机容量(kw) Max. equipment capacity	主机尺寸(m) Main machine dimensions	占用平面m² occupied area
XSG-2	200	300-800	10-20	5-9	250x2800	3500x2500
XSG-3	300	600-1500	20-50	8-15	400x3300	3800x2700
XSG-4	400	1250-2500	25-70	10-17.5	500x3500	4000x3000
XSG-5	500	1500-4000	30-100	12-24	600x4000	4200x3200
XSG-6	600	2500-5000	40-200	20-29	700x4200	4250x3250
XSG-8	800	3000-8000	60-600	24-35	900x4600	4500x3500
XSG-10	1000	5000-12500	100-1000	40-62	1100x5000	4750x3750
XSG-12	1200	10000-20000	150-1300	50-89	1300x5200	5000x4000
XSG-14	1400	14000-27000	200-1600	60-105	1500x5400	5250x4250
XSG-16	1600	18700-36000	250-2000	70-105	1700x6000	5500x4500

注：1.水份蒸发量以进风温度180℃，出风80℃计。2.装机容量为基本数据，可根据物料性能改变。3.占地面积根据实际情况布置，表中数据仅供参考。
 Note: 1. The evaporated amount of moisture is calculated when the temperature of inlet is 180°C and the temperature of outlet is 80°C. 2. Beside the models above mentioned, specification can be made as request. 3. Occupied area will be different because of different environment.

▶ 原理 Principle

空气经加热净化后，由引风机从下部导入，穿过料斗的孔网板。在工作室内，经搅拌和负压作用形成流态化，水份快速蒸发后随着排气带走，物料快速干燥。
Purified and heated air is introduced from the bottom through suction fan and passed through the screen plate of raw material. In the work chamber, the state of fluidization is formed through stirring and negative pressure. The moisture is evaporated and removed rapidly and the raw material is dried quickly.

▶ 特点 Features

- ◇ 流化床为圆形结构，避免死角。
- ◇ 料斗设置搅拌，避免潮湿物料团聚及干燥时形成沟流。
- ◇ 采用翻倾卸料，方便迅速彻底，亦可按要求设计自动进出料系统。
- ◇ 密闭负压操作，气体经过过滤。操作简便，清洗方便，是符合“GMP”要求的理想设备。
- ◇ 干燥速度快，温度均匀，每批干燥时间一般在20-30分钟。

- ◇ The structure of fluidization bed is of round so as to avoid dead corner.
- ◇ Inside the hopper there is a stir in order to avoid agglomeration of raw material and forming canal of flow.
- ◇ The granule is discharged through the method of turning over. It is very convenient and full. The discharged system can be designed as request too.
- ◇ It is operated at he conditions of negative pressure and seal. The air is filtered. Therefore it is simple in operation and convenient for cleaning. It is an ideal equipment that is in conformity with the requirements of GMP.
- ◇ The drying speed is fast and the temperature is uniform. In general the drying time is 20~30 minutes.

▶ 结构示意图 Sketch of structure

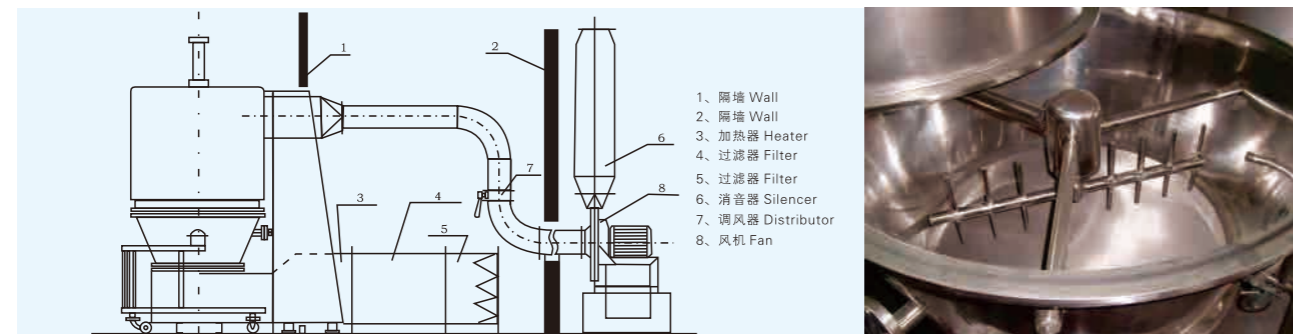

▶ 技术参数 Technical parameters

项目 Item	单位 Unit	型号 Type								
投料 capacity	Kg	60	100	120	150	200	300	500	1000	
风机 fan	风量 velocity	m³/h	2361	3488	4000	4901	6032	7800	10800	1500
	风压 air pressure	mmH ₂ O	594	533	533	679	787	950	950	1200
	功率 power	kw	7.5	11	11	15	22	30	37	75
搅拌功率 stirring power	kw	0.4	0.55	0.55	1.1	1.1	1.1	1.5	2.2	
搅拌转速 stirring speed	rpm				11					
蒸汽耗量 consume of steam	kg/h	141	170	170	240	282	366	451	800	
操作时间 time of operation	min	15-30(视物料情况而定 depends on material)								
主机高度 height of main machine	mm	2700	2900	2900	2900	3100	3600	3850	5800	

▶ 特点 Features

- ◇ 流态化干燥、热质传递快；
- ◇ 在封闭负压下操作，无粉尘飞扬；
- ◇ 采用抗静电过滤材料，操作安全；
- ◇ 设备无死角，清洗彻底，无交叉污染；
- ◇ 满足GMP规范要求。
- ◇ Fluid bed to achieve fast heat transmission of medium.
- ◇ Seal negative pressure operation, there is no dust.
- ◇ Because of using anti-static material as filter, it is safe in operation;
- ◇ The equipment has no dead corner so it is easy to clean fully and there is no cross pollution;
- ◇ It is conformity with the requirements of GMP.

▶ 应用 Applications

本机主要适用于医药、食品、化工等行业进行粉末或颗粒物料的干燥。
The machine is main used for drying powder or granules from pharmaceutical, foodstuff, chemical and so on industries.



▶ 技术参数 Technical parameters

机型 type		3	5	30	60	120	200	300	500	1000
项目 item	单位 unit									
原料容器 container of raw material	直径 dim.	300	400	700	1000	1200	1400	1600	1800	2200
	容积 volume	12	22	100	220	420	670	1000	1500	2500
生产能力 production capacity	最小 min	1.6	4	15	30	80	100	150	250	500
	最大 max	4	6	36	72	140	240	360	600	1100
蒸汽耗量 consume of steam	kg/batch	12	23	70	140	211	282	366	465	800
压缩空气量 amount of compressed air	m³/min	0.3	0.3	0.3	0.6	0.6	0.9	1.1	1.6	1.5
风机功率 Power of fan	kw	2.2	4	5.5	11	18.5	22	30	45	75
温度 Temperature	°c	常温~120℃自动调节 (Adjustable from ambient to 120)								
物料收率 Yield	%	> 99								
操作时间 Option time	min	15-30(视具体物料而定 depends on material)								
终湿含量 Content at final term.	%	-0.2(视具体物料而定 depends on material)								
噪音 Noise	dB	≤ 75								
主机高度 Height of main machine	mm	2100	2300	2500	3000	3300	3800	4000	4800	6200

概述 Descriptions

沸腾干燥，又称流化床，它是由空气过滤器、加热器、沸腾床主机、旋风分离器、布袋除尘器、高压离心风机、操作台组成，由于干燥物料的性质不同，配套除尘设备时，可按需要考虑，可同时选择旋风分离器、布袋除尘器，也可选择其中一种，一般来说比重较大的如冲剂及颗粒物料干燥只需选择旋风分离器，比重较轻的小颗粒状和粉状物料需配套布袋除尘器，并备有气力送料装置及皮带输送机供选择。

散粒状固体物料由加料器加入流化床干燥器中，过滤后的洁净空气加热后由鼓风机送入流化床底部经分布板与固体物料接触，形成流态化达到气固的热质交换。物料干燥后由排料口排出，废气由沸腾床顶部排出经旋风除尘器组和布袋除尘器回收固体粉料后排空。

蒸汽、电、热风炉均可配用(按用户要求配套)。

它适用于散粒状物料的干燥，如：医药药品中的原料药、压片颗粒料、中药冲剂、化工原料中的塑料树脂、柠檬酸和其他粉状、颗粒状物料的干燥除湿，还用于食品饮料冲剂，粮食加工、玉米胚芽、饲料等的干燥。物料的粒径最大可达6mm，最佳为0.5~3mm。



Boiling dryer is also called as fluidized-bed. It consists of air filter, heater, fluidized-bed main machine, feeder, cyclone separator, cloth bag duster, high-pressure centrifuge fan and operation table. Because the properties of raw materials exist difference, when equip the dust removing equipment, it should consider the practical need. It can select cyclone separator and cloth bag duster at the same time or one of them. In general speaking, it needs to select cyclone separator only for raw material that is large in specific gravity and cloth bag duster for powder and small granule raw materials that is light in specific gravity. Meanwhile there is air feeding device and belt conveyor for selection.

Separated granule solid raw material is fed into fluidized-bed drier through feeder. Fresh air through filtering and heating is sent to the bottom of fluidizedbed by fan and contacts with solid raw material on distributing plate. In this way the fluidized state is formed and the heat exchange between air and solid is carried out. The dried raw material is discharged from outlet and wasted gas is exhausted from the top of fluidized-bed where catches solid powder through cyclone separator, cloth bag duster.

Steam, electricity or hot air furnace can be used (it can be supplied as request) It is suitable for drying separated granule such as, raw material of pharmaceutical industry, tablet, tablet of drink of Chinese traditional medicines; plastic resin, citric acid, other powder and granule of chemical industry, powder of drink, corn embryo feed of foodstuff industry and so on. The Max diameter of raw material to be dried will 6 mm and the best diameter will be 0.5~3 mm.



实际使用中的非标设计大型沸腾床 Fluidizing dryers under production on-site

特点 Features

沸腾床干燥机可实行自动化生产，是连续式干燥设备。干燥速度快，温度低，能保证产品质量，符合药品生产GMP要求。蒸汽、电、热风炉均可配用。

This fluidized bed dryer can achieve automation and continuous drying process. It has a high drying speed and a low temperature and the product quality can be ensured, meeting GMP requirements. The heating resource can be steam, electricity or furnace.

工艺流程 Technological process

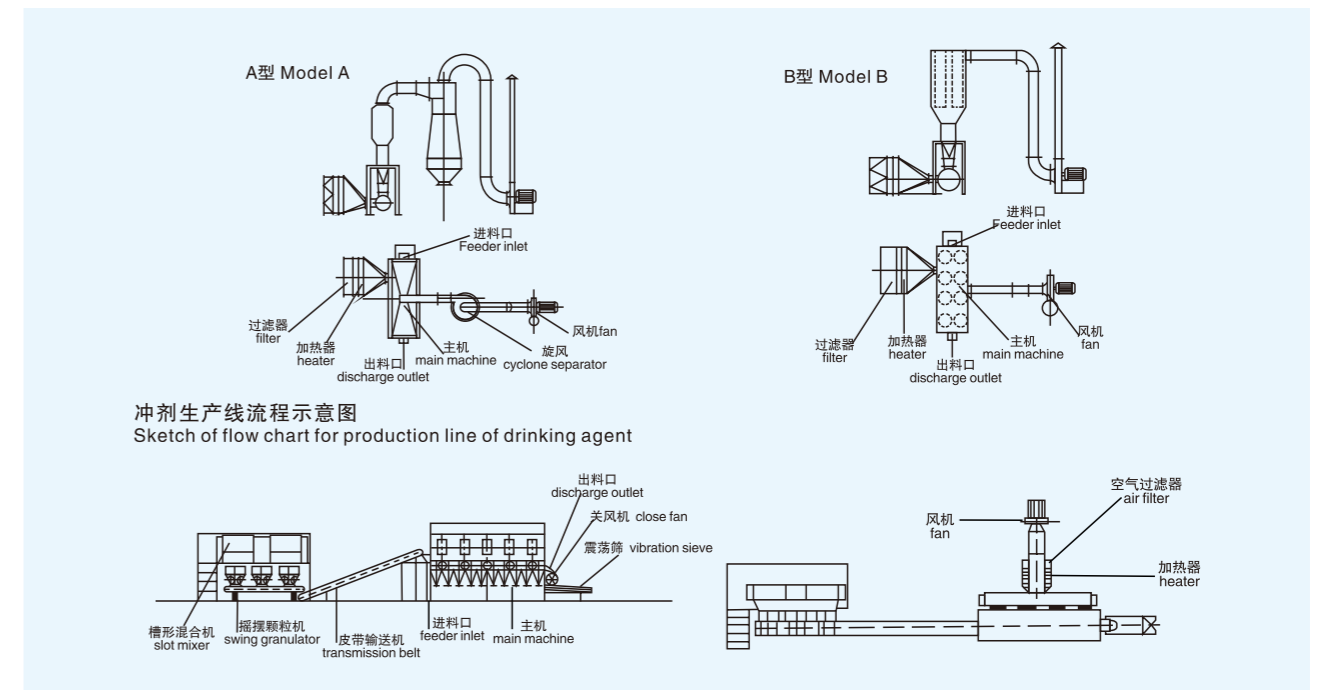

技术参数 Technical parameters

型号规格 model and specifications	XF 0.25-1 (原XF10)	XF 0.25-2 (原XF20)	XF 0.25-3 (原XF30)	XF 0.25-6	XF 0.3-2	XF 0.3-4	XF 0.3-6	XF 0.3-8	XF 0.3-10	XF 0.4-4	XF 0.4-6
床层面积 area of bed layer (m ²)	0.25	0.5	1.0	1.5	0.6	1.2	1.8	2.4	3.0	1.6	2.4
干燥能力 drying capacity (kg H ₂ O/h)	10~15	20~25	30~45	52~75	~30	42~60	63~90	84~120	105~150	56~80	84~120
风机功率 Power of fan (kw)	5.5	7.5	15	22	7.5	18.5	30	37	48	30	37
进风温度 temperature of air in (°C)	120~140	120~140	120~140	120~140	120~140	120~140	120~140	120~140	120~140	120~140	120~140
物料温度 temperature of air in (°C)	40~60	40~60	40~60	40~60	40~60	40~60	40~60	40~60	40~60	40~60	40~60
外形尺寸(主机) overall dimensions (main machine) L(长)×W(宽)×H(高)(m)	1×0.6×3.35	2×0.6×3.35	4×0.6×3.35	6×0.6×3.35	2×0.7×3.4	4×0.7×3.4	6×0.7×3.4	8×0.7×3.4	10×0.7×3.4	4×1×3.58	6×1×3.58
占地面积 occupied area (m ²)	18	25	35	40	25	38	45	56	70	18	56

型号规格 model and specifications	XF 0.4-8	XF 0.4-10	XF 0.4-12	XF 0.5-4 (原XF50)	XF 0.5-6	XF 0.5-8	XF 0.5-10	XF 0.5-12	XF 0.5-14	XF 0.5-16	XF 0.5-18
床层面积 area of bed layer (m ²)	3.2	4.0	4.8	2.0	3.0	4.0	5.0	6.0	7.0	8.0	9.0
干燥能力 drying capacity (kg H ₂ O/h)	112~160	140~200	168~240	70~100	105~150	140~200	175~250	210~300	245~350	280~400	315~450
风机功率 Power of fan (kw)	48	70	70	30	48	70	105	140	147	169	197
进风温度 temperature of air in (°C)	120~140	120~140	120~140	120~140	120~140	120~140	120~140	120~140	120~140	120~140	120~140
物料温度 temperature of air in (°C)	40~60	40~60	40~60	40~60	40~60	40~60	40~60	40~60	40~60	40~60	40~60
外形尺寸(主机) overall dimensions (main machine) L(长)×W(宽)×H(高)(m)	8×1×3.58	10×1×3.58	12×1×3.58	4×1.2×4.1	6×1.2×4.1	8×1.2×4.1	10×1.2×4.1	12×1.2×4.1	14×1.2×4.1	16×1.2×4.1	18×1.2×4.1
占地面积 occupied area (m ²)	74	82	96	50	70	82	100	140	180	225	268

注：一、加料方式有：1.星形加料。2.星形加料式和气加输送并用。3.皮带输送。4.用户自定。二、可实现自动化生产。三、除以上型外，可为用户作特殊设计。

四、根据物料不同，风机功率亦不同。
 Note: 1. The feeding way has: (A) Star feeding (B) Combining star feeding and air conveyor (C) Belt conveying (D) decided by customer
 2. Automatic production can be realized. 3. Besides the model above mentioned, the special model can also be designed and manufactured as request.
 4. According different raw material, the power of fan will be differ.

原理 Principle

QG系列脉冲式气流干燥机是一种批量大，效率较高的干燥设备，它采用瞬间干燥的原理，利用载热空气的快速运动，带动湿物料，使湿物料悬浮在热空气中，这样强化了整个干燥过程，提高了传热传质的速率，经过气流干燥的物料，非结合水分几乎可以全部除去，并且所干燥的物料，不会产生变质现象，产量可比一般干燥机干燥有显著提高，用户可在短期内取得较高的经济效益。

QG airstreams pulse drier is a large quantity production drier, it adopt instant drying principle, utilize hot air's quick move to drive damp raw material and make it floats in the hot air, this can strengthen the whole drying process, improve the speed of hot exchange. If raw material is dried by this equipment, non-combined moisture can be removed completely, dried material never metamorphosed, compared with general drier, output is remarkably raised.



适用物料 Materials

这种类型的设备，适应的物料比较多，除基本型提及的物料外，还有：安眠酮、A. B. C中间体、A. B. S树脂、A. S. C、白炭黑、苯茶吡唑酮、茶粕、草酸催化剂、促进剂m. d. m、触媒、沉淀炭粉、对乙酰氨基苯磺酰氯、对氨基水杨酸、哆耳玛托、对苯二酸、二乙苯铵、二氧化钛、活性炭、氟硅酸钠、氟石矿、硅胶粉末、合成树脂、磷酸钙、聚丙烯树脂、金霉素、焦硅酸钠、糠氨酸咖啡渣四环素、三氧化铁、碳酸钙、玉米蛋白、氧化铁、石膏缓凝剂等。

The kinds of dry equipment can be suitable for more raw materials. Besides the raw materials mentioned in basic type drier, the following raw materials can also be dried. They are hyminal, ABC intermediate, ABS resin, ASC, white carbon black, phthalimidine, catalyst for oxalic acid, accelerant m.d.m, catalyst, deposited carbon powder, p-acetamidobenzene sulfonyl chloride, sodium para-aminosalicylate, terephthalic acid, diethylaniline, titanium dioxide, active carbon, sodium fluosilicate, fluoric ore, ammonium sulphate, silica gel powder, synthesis resin, calcium hydrogen phosphate, PP, aureomycin, sodium disilicate, oral glucose, sodium sulfate, sulphide ore. Phosphorus ore powder, blue BB, PVC, phosphate fertilizer, aureomycin, ferric oxide, calcium carbonate, ilmenite, copper ore, potato, tail coal, stearate, maize protein, medicine, dose, ferric oxide, calcium sulphate retarder and so on.

技术参数 Technical parameters

型号 spec	蒸发水份 moisture to be evaporated(kg/h)	装机功率(kw) power	占地面积(m ²) occupied area	高度(m) Height
QG 50	50	7	20	14
QG 100	100	13	32	14
QG 200*	200	21	40	15
QG 250	250	24	64	15
QG 500	500	43	96	18
QG 1000*	1000	100	120	18
QG 1500*	1500	150	200	20

注：部分参数设计时视不同物料有所调整，以设计为准。表中水份蒸发量以干燥玉米淀粉为准。

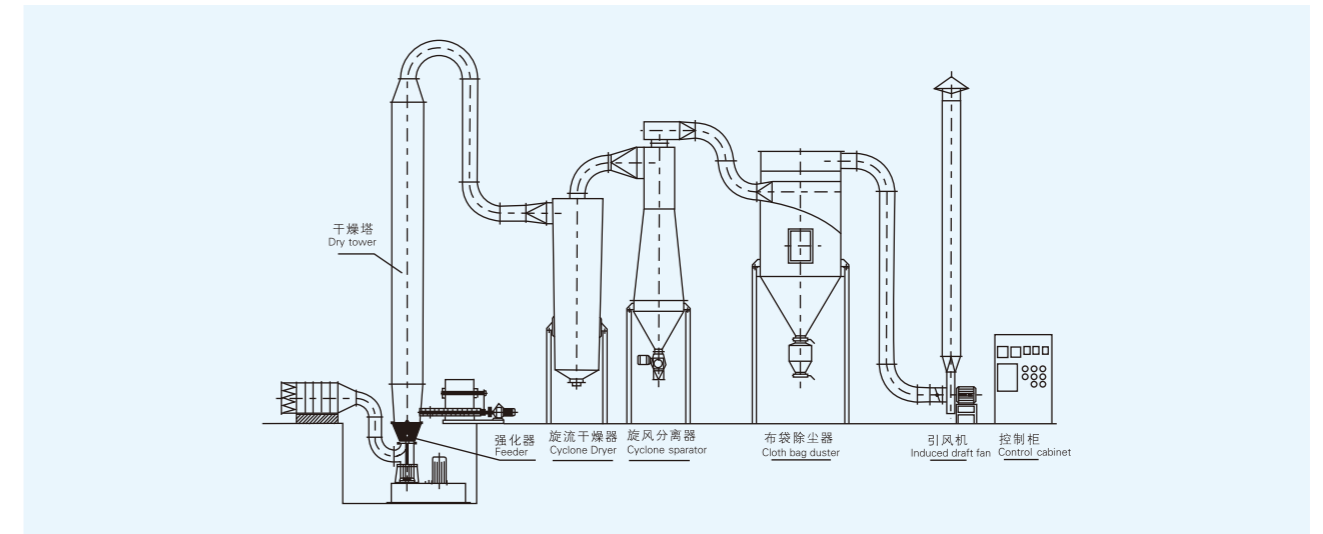

原理 Principle

底部强化器设计独特，搅拌齿为菱形，其流线性能使风阻达到最小，设置在圆锥形料斗内，分动刀和定刀，粉碎效果显著，使下落的结块物料迅速粉碎为适合气流干燥的粉粒料，搅拌的另一个主要作用是分散物料，加大了与料斗下面进来的高速热风的接触面积，于是料斗区形成了一个强烈传热传质的流化床，大部分湿分在料斗区被干燥。随着干燥的进行，变轻变细的干料受气流作用明显，与气流一起上升并进一步干燥，最后从干燥塔顶部出来进入物料收集系统。

The bottom of dryer has the unique enhanced design, stirring rack is diamond shaped, its linear flow design can reduce wind resistance into a minimum degree, also the grinding knives are equipped at the bottom, the results of grinding are obvious, the falling the materials can be rapidly crushed into powders which are suitable for air flow drying, another function of stirring is dispersing materials, thus can enlarge the contacting area with high speed hot air coming from the bottom, and most of moisture is dried during this stage, and then the dried material becomes lighter and lighter, and flow up with hot air, finally comes out from the top of dryer and goes into material collecting system.

适用物料 Materials

本机特别适合处理含湿量比较大的呈膏糊状的湿物料，以及用其他气流干燥方法无法干燥的物料，适用于滤饼、膏状、带有一定粘性、要求成品为粉末的产品。

This dryer is suitable for the raw materials that contains high moisture and appear paste and other raw materials that can not be dried with other drying methods, also apply to the cake, paste, With a certain viscosity, require finished products for the powder.

技术参数 Technical parameters

型号 Spec	蒸发能力 Kg H ₂ O/h	功率kw power kw	占地面积m ² occupied area m ²	主塔高度m height m
FG-400	40-70	17	35	5
FG-600	80-150	29	50	6
FG-800	150-250	45	65	7
FG-1000	230-420	72	75	8
FG-1200	300-600	104	100	9

注：

- 1、水分蒸发量是以进风温度为180℃、出风温度为80℃时每小时蒸发的水分；
- 2、除以上型号外可为用户作特殊设计；
- 3、以上装机容量为标准配套，根据物料不同功率会有变动。

Note:

- 1.The evaporated amount of moisture is calculated when the temperature of inlet is 180℃ and the temperature of outlet is 80℃.
- 2.Besides the models above mentioned, special specification can also be made as request.
- 3.The equipped capacity above mentioned is standard. The power can also be decreased in accordance with practical conditions.

概述 Descriptions

回转滚筒干燥机(简称回转窑)是一种应用非常广泛的干燥设备,在化工、轻工、煤炭、建材以及矿冶行业占有重要地位。近年来,回转圆筒干燥机的发展非常迅速,出现了许多新形式。综合其特点,主要表现在三个方面,即:设备规格大型化、结构型式多样化以及节能和自动化。

Rotary drum dryer (the dryer drum) is a very wide range of drying equipment in the chemical industry, light industry, coal, building materials and mining and metallurgy industry occupies an important position. In recent years, rotary drum dryer has developed rapidly, many new forms. Its comprehensive features, mainly in three aspects, namely: large-scale equipment specification, structure type diversification and energy efficiency and automation.

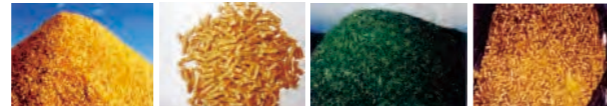

原理 Principle

湿物料从干燥机一端投入后,在内筒均布的抄板器翻动下,物料在干燥器内均匀分布与分散,且与并流(逆流)的热空气充分接触,加快了干燥传流、传质推动力。在干燥过程中,物料在带有倾斜的抄板和热气流作用下,可控地运动至干燥机另一端星形卸料阀排出成品。

When the damp raw material is fed from one terminal, it is turned over through blades that are distributed inside the cylinder and will be distributed uniformly in the drier and contact fully with the countercurrent hot air. In this way, the process of heat conduction is increased. During the period of dry, under the effect of incine blades and hot air stream, raw material can be moved to the star section of drier and discharged from disharged form discharging valve.

特点 Features

- ◇ 转筒干燥器机械化程度高,生产能力较大。
- ◇ 流体通过筒体阻力小,功能消耗低。
- ◇ 对物料特性的适应性比较强。
- ◇ 操作稳定,操作费用较低,产品干燥的均匀性好。

- ◇ High in the etent of mechanization and strong in production capacity.
- ◇ The resistance for fluid passing through the cylinder is small. The consumption of power and energy is low.
- ◇ It has strong adaptability to the properties of raw material. The operation is stable. The cost of operation is cheap.
- ◇ The uniformity of dried substance is good.

应用 Applications

适用于化工、矿山、冶金等行业大颗粒,比重大物料干燥,如:矿石、高炉矿渣、煤、金属粉末、磷肥、硫铵。对有特殊要求的粉状、颗粒状物料的干燥,如:HP发泡剂、酒糟渣、轻质碳酸钙、活性白土、磁粉、石墨、药渣。要求低温干燥,且需大批量连续干燥的物料。

It is suitable for drying the following raw materials. They are granules with heavy specific gravity in chemical industry, mine industry, metallurgy industry such as ore, slag, coal, metallic powder, phosphorus fertilizer, ammonia sulfate. Moreover for raw materials that are granules with special requirements, such as HP vesicant, less, light calcium carbonate, active white earth, magnetic powder, graphite, lag of medicine and raw materials that need low temperature and in batch continuously.

技术参数 Technical parameters

规格 Item(m)	生产能力 Productive capacity(t/h)	筒体速度 Revolution(r/min)	电机功率 Motor power(kW)	安装角度 Install angle(度)	出料湿度 Temp.of final
Φ 1.0×5.0	0.5~1.2	0.6~6	4	3~5	≤1.5%
Φ 1.2×6~10	1.5~3	0.6~6	5.5	3~5	≤1.5%
Φ 1.5×12~18	3~5.5	0.6~6	15	3~5	≤1.5%
Φ 1.8×12~18	5~6.5	0.6~6	18.5	3~5	≤1.5%
Φ 2.2×12~22	7~12	0.6~6	22	3~5	≤1.5%
Φ 2.4×15~20	9~15	0.6~6	30	3~5	≤1.5%
Φ 3.0×25	16	0.6~6	55	3~5	≤1.5%

应用 Applications

型号Model	直接加热顺流式 direct heating clockwise way	直接加热顺流式 direct heating clockwise way	直接加热逆流式 direct heating counterclockwise way	直接加热逆流式 direct heating counterclockwise way	复合加热 compound heating	复合加热 compound heating
物料种类 Kinds of raw material	矿石Ore	HP发泡剂 HPvesicant	高炉矿渣 Slag of blast furnace	硫铵 Ammonium sulphate	磷肥 Phosphorus fertilizer	煤 Coal
处理量 Amount to be treated(kg/h)	1000	466	15000	20000	12000	5000
初含水量 Primary moisture(%)	30	13	6	1.5	5	6.5
终含水量 Final moisture(%)	15	0.3	1	0.1	0.1	0.1
平均粒径 Average diameter(mm)	6.5	0.05	4.7	0.5~0.7	0.5	5
物料堆积比重 Thickness of raw material(kg/m³)	770	800	1890	1100	1500	750
热风量Amount of hot air (m³/kg)	39000	5400	10750	9800	6500	16000
入口气体温度Temperature of air at inlet(°C)	600	165	500	180	650	570
物料出口温度Temperature of raw material at outlet(°C)		42	100	70	80	75
加热方式Way of heating	煤气Gas	蒸气式电加热 Steam,electric heating	重油Heavy oil	燃煤热风炉coal fuel hot air furnace	重油Heavy oil	重油Heavy oil
装料系数Filling coefficient		6.3	7	7.5	7.8	18
转速Revolution(r.p.m)	4	4	3.5	3	4	2
倾斜度Gradient(m/m)	0.04	0.005	0.03	0.05	0.05	0.043
抄板数目Quantity of stirring-up rake	12	24	12	22	内筒外圈8 Outer of inner cylinder8 外筒内圈16 Inner of outer cylinder16	内筒外圈6 Outer of inner cylinder6 外筒内圈12 Inner of outer cylinder12
干燥器直径diameter of dryer(m)	2.0	1.5	2	2.3	内筒外圈2 Outer of inner cylinder2 外筒内圈0.84 Inner of outer cylinder0.84	内筒外圈2.4 Outer of inner cylinder2.4 外筒内圈0.95 Inner of outer cylinder0.95
干燥器长度Length of dryer(m)	20	12	17	15	10	16
驱动功率Driving Power(kW)	22	7.5	15	11	11	15



概述 Descriptions

滚筒刮板干燥机是一种内加热传导型转动连续干燥设备。旋转的滚筒通过其下部料槽，粘附着一厚度的料膜，热量通过管道输送至滚筒内壁，传导到滚筒外壁，再传导给料膜，使料膜中的湿度得到蒸发、脱湿、使含湿分的物料得到干燥。干燥好的物料被装置在滚筒表面的刮刀铲离滚筒，到置于刮刀下方的螺旋输送机，通过螺旋输送机将干物料集中、包装。

Drum dryer is a kind of rotating continuous drying equipment with internal heating conducting-style. Certain thickness of materials film attach to the drum from material liquid vessel under the drum. Heat is transferred to the internal wall of the cylinder through pipes and then to the external wall and to materials film, to evaporate the moisture in materials film so as to dry materials. Dried products are then scraped off by the blade fitted on the surface of the cylinder, fall down to the spiral conveyor under the blade, and are conveyed, collected and packed.

应用 Applications

HG系列滚筒刮板干燥机广泛用于食品、化工、医药等行业粘性、膏糊状物料制片、干燥等工序。

Such processes as the HG series cylinder dryer is used in such trades as the food, chemical industry, medicine, etc. viscosity, lotion pastel supplies film-making, dry extensively.

特点 Features

- ◇ 热效率高。因滚筒干燥机传热机理属热传导，传热方向在整个操作周期中保持一致，除盖散热和热辐射损失外，其余热量全部都用于筒料膜湿分的蒸发上，热效率可达80%~90%。
- ◇ 操作弹性大，适用性广。可调整滚筒干燥机的诸多干燥因素。如进料的浓度、涂料料膜的厚度、加热介质的温度、滚筒的转动速度等，都可以改变滚筒干燥机的干燥效率，且诸多因素互无牵连。这给滚筒干燥操作带来很大的方便，使之能适应多种物料的干燥和不同产量的要求。
- ◇ 干燥时间短。物料的干燥周期一般只有10~300秒，在适合于热敏性物料。若将滚筒干燥机设置在真空中，则可在减压条件下运行。
- ◇ 干燥速率大。由于涂料抹于筒壁的料膜很薄，一般在0.3~1.5mm，且传热、传质方向一致，料膜表面可保持20~70kg·H₂O/m²·h的蒸发量。



◇ High heat efficiency. The principle of heat transfer of the cylinder dryer is heat conduction and the conducting direction keeps identical in the whole operation circle. Except heat loss of end cover and radiation loss, all heat can be used for evaporation of wet materials on the wall of the cylinder. The efficiency can reach 80~90%.

◇ Large operation elasticity and wide application. Various drying factors of the dryer can be adjusted, such as concentration of feeding liquid/thickness of material film, temperature of heating medium, rotating speed of the drum etc. which can change drying speed of the under dryer. As these factors have no interrelations each other, it brings great convenience to dry operation and makes it applicable to dry various materials and to meet different requirements of production.

◇ Short drying period. The drying period of materials is normally 10 to 300 seconds, so it is suitable for heat-sensitive materials. It also can be pressure reducing operated if it is put in vacuum vessel.

◇ Fast drying rate. As film of materials coated on the wall of the cylinder is very thin. Normal, thickness is 0.3 to 1.5mm, plus directions of heat and mass transmitting are identical, the evaporation strength on the surface of the film can be 20~70 kg·H₂O/m²·h.

技术参数 Technical parameters

规格 model size	滚筒尺寸 sizes of cylinder diameter × length (mm)	有效加热面积 effective heating area(m ²)	干燥能力 drying capacity (Kg/h)	蒸汽耗量 steam consumption(kg/h)	电机功率 power of motor (kw)	外形尺寸 sizes L × W × H (mm)	重量 weight (kg)
HG-600	Φ600 × 800	1.12	40-70	100-175	1.1	1700 × 800 × 1500	850
HG-700	Φ700 × 1000	1.65	60-90	150-225	2.05	2100 × 1000 × 1800	1210
HG-800	Φ800 × 1200	2.26	90-130	225-325	3.75	2500 × 1100 × 1980	1700
HG-1000	Φ1000 × 1400	3.30	130-190	325-475	4.75	2700 × 1300 × 2250	2100
HG-1200	Φ1200 × 1500	4.24	160-250	400-625	4.75	2800 × 1500 × 2450	2650
HG-1400	Φ1400 × 1600	5.28	210-310	525-775	6.25	3150 × 1700 × 2800	3220
HG-1600	Φ1600 × 1800	6.79	270-400	675-1000	6.25	3350 × 1900 × 3150	4350
HG-1800	Φ1800 × 2000	8.48	330-500	825-1250	8.6	3600 × 2050 × 3500	5100
HG-1800A	Φ1800 × 2000	10.60	420-630	1050-1575	8.6	4100 × 2050 × 3500	6150

注：部分参数设计时视不同物料有所调整，以设计为准。

概述 Descriptions

盘式连续干燥机是一种高效的传导型连续干燥设备，其独特的结构和工作原理决定了它具有热效率高、能耗低、占地面积小、配置简单、操作控制方便、操作环境好等特点。广泛适用于化工、医药、农药、食品、饲料、农副产品加工等行业的干燥作业。在各行各业使用实践中深受好评。可分为常压、密闭、真空三大类型；1200、1500、2200、3000四种规格；A(碳钢)、B(接触物料部分不锈钢)、C在B的基础上、增加蒸汽管路、主轴及支架为不锈钢，筒体和顶盖内衬不锈钢)三种材质，干燥面积4~180m²，共几百种型号的系列产品，并能提供与之相配套的辅助设备，可满足用户对各种物料进行干燥的需要。

PLG Series Continual Plate Dryer Descriptions Plate dryer is a kind of high effective conducting and continuous drying equipment. Its unique structure and operating principle determine that it has advantages of high heat efficiency, low energy consumption, small occupying area, simple configuration, easy operating and control as well as friendly operating environment etc. It can be widely used in drying process in the fields of chemical industry, Pharmaceuticals, agricultural chemicals, foodstuff, fodder, process of agricultural and sideline products etc, and is well received by various sectors in their practical usage. Now there are three big categories, named normal pressure, closed and vacuum styles; four sizes of 1200, 1500, 2200 and 3000; and three kinds of materials, namely A(carbon steel), B(stainless steel used for those all parts where materials are contacted) and C(on the basis of B to add stainless steel materials for vapor pipes, main shaft and support, and stainless steel linings for cylinder body and top cover). With a drying area being from 4 to 180 square metres, now we have hundreds of models of series products and various kinds of auxiliary devices available to meet requirements of drying materials for customers.

特点 Features

(一) 调控容易、适用性强

- 1.通过调整料层厚度、主轴转速、耙臂数量、耙叶型式和尺寸可使干燥过程达到最佳。
- 2.每层干燥盘皆可单独通入热介质或冷介质、对物料进行加热或冷却，物料温度控制准确、容易。
- 3.物料的停留时间可以精确调整。
- 4.物料流向单一、无返混现象、干燥均匀、质量稳定、不需再混合。

(二) 操作简单、容易

- 1.干燥器的开车、停车操作非常简单。
- 2.停止进料后，传送物料的耙叶能很快地排空干燥器内的物料。
- 3.通过特殊的大规格检视门的视镜，可以对设备内进行很仔细的观察。

(三) 能耗低

- 1.料层很薄，主轴转速低，物料传送系统需要的功率小、电耗少。
- 2.以传导热进行干燥，热效率高，能量消耗低。

(四) 操作环境好，可回收溶剂，粉尘排放符合要求

- 1.常压型：由于设备内气流速度低，而且设备内湿度分布上高下低，粉尘很难浮到设备顶部，所以顶部排湿口排出的尾气中几乎不含有粉尘。
- 2.密闭型：配备溶剂回收装置，可方便地回收在湿气体中的有机溶剂。溶剂回收装置简单，回收率高，对于易燃、易爆、有毒和易氧化的物料，可用氮气作为载湿气体进行闭路循环，使之安全操作。特别适用于易燃、易爆、有毒物料的干燥。
- 3.真空型：在真空状态下操作的盘式干燥器，特别适用于热敏性物料的干燥。

(五) 安装方便，占地面积小

- 1.干燥器整体出厂，整体运输，只需吊装就位，安装定位非常容易。
- 2.由于干燥盘层式布置、立式安装，即使干燥面积很大，占地面积也很小。

(1) Easy control, wide application

1. Regulate thickness of materials, rotating speed of main shaft, number of harrow's arm, style of and sizes harrows achieve best drying process.
2. Each layer of drying plate can be fed with hot or cold media individually to heat or cold materials and make temperature control accurate and easy.
3. Dwell time of materials can be accurately adjusted.
4. Single flowing direction of materials without return flowing and mixing, uniform drying and stable quality, no re-mixing is required.

(2) Easy and simple operation

1. Start stop of dryer is quite simple
2. After material feeding is stopped, they can be easily discharged out of the dryer by harrows.
3. Careful cleaning and observation can be carried inside the equipment through large-scale viewing window.

(3) Low energy consumption

1. Thin layer of materials, low speed of main shaft, small power and energy required for conveying system of materials.
2. Dry by conducting heat so it has high heating efficiency and low energy consumption.

(4) Good operation environment, solvent can be recovered and powder discharge meet the requirements of exhaust.

1. Normal pressure type: as low speed of air flow inside the equipment and moisture being high in upper part and low in lower part, dust powder couldn't float to the equipment, so there is almost no dust powder in tail gas discharged from the moist discharge port on the top.
2. Closed type: equipped with solvent recovery device that can recover organic solvent easily from moist-carrier gas. The solvent recovery device has simple structure and high recovery rate, and nitrogen can be used as moist-carrier gas in closed circulation for those subject to burning, explosion and oxidation, and poisonous materials in order for safe operation. Especially suitable for drying of flammable, explosive and poisonous materials.
3. Vacuum type: if the plate dryer is operating under vacuum state, it is particularly suitable for drying heat sensitive materials.

(5) Easy installation and small occupying area.

1. As the dryer is in a whole for delivery, it is quite easy to install and fix at site only by hoisting.
2. As drying plates being arranged by layers and installed vertically, it takes a small occupying area though drying area is large.



技术特征 Technical

(一) 干燥盘

- 1.设计压力：一般为0.4MPa，最大可达1.6MPa。
- 2.最高使用压力：一般≤0.4MPa，最高可达1.6MPa。
- 3.加热介质：蒸汽、热水、导热油、干燥盘温度100℃时使用热水加热，100℃~150℃时用≤0.4MPa饱和水蒸汽或者过热蒸汽加热，150℃~320℃时用导热油加热，>320℃时可采用电、导热油、熔盐等方式加热。

(二) 物料传送系统

- 1.主轴转速：1~10转分，电磁或变频无极调速。
- 2.耙臂：每层干燥盘上有2~8支固定在主轴上的耙臂。
- 3.耙叶：绞接在耙臂上，能随盘面上下浮动保持接触，有多种形式。
- 4.碾滚：对易结块和需要粉碎的物料，在适当位置配加碾滚，可以强化传热和干燥过程。

(三) 壳体

有常压、密闭、真空三种型式

- 1.常压型：圆筒或八棱柱型，有整体和对开两种结构。加热介质进出口主管道可以在壳体内，也可以在壳体外。
- 2.密闭型：圆筒型壳体，能承受5Kpa内压，加热介质进出口主管道可以在壳体内，也可以在壳体外。
- 3.真空型：圆筒型壳体，设计压力为0.1Mpa，加热介质进出口主管道在壳体内。

(四) 空气加热器

一般在蒸发量较大的情况下使用，以增强干燥效率。

1. Drying plate

- (1). Designing pressure: general is 0.4MPa, Max. can reach 1.6 Mpa.
- (2). Work pressure: general is less than 0.4Mpa, and Max. can reach 1.6 Mpa.
- (3). Heating medium: steam, hot water, oil. When the drying plates' temperature is 100℃, hot water can be used; when 100℃~150℃, it will be saturated water steam ≤0.4Mpa or steam-gas, and when 150℃~320℃, it will be oil; when >320℃ it will be heated by electric, oil of fused salt.

2. Material transmission system

- (1). headstock revolution: 1~10 rpm, electromagnetism of transducer timing.
- (2). harrow arm: There are 2 to 8 pieces arm that be fixed on the headstock on the every layers.
- (3). Harrow's blade: Surrounding the harrow's blade, float together with the surface of the plate to keep contact. There're various of types.
- (4). Roller: for the products easily agglomerate, or with the requirements of grinding, the heat transfer and drying process might be reinforced by placing roller(s) at the appropriate place(s).

3. Shell There're three types for option: normal pressure, sealed and vacuum

- (1). Normal pressure:
- (2). Sealed: Cylindrical shell, could bear the interior pressure of 5KPa, the main ducts of the inlet and outlet of heating media might be inside of the shell or outside.
- (3). Vacuum: Cylindrical shell, could bear the exterior pressure of 0.1MPa. The main ducts of inlet and outlet is inside of the shell.

4. Air heater:

Normal for the application of big evaporation capacity to increase drying efficiency.

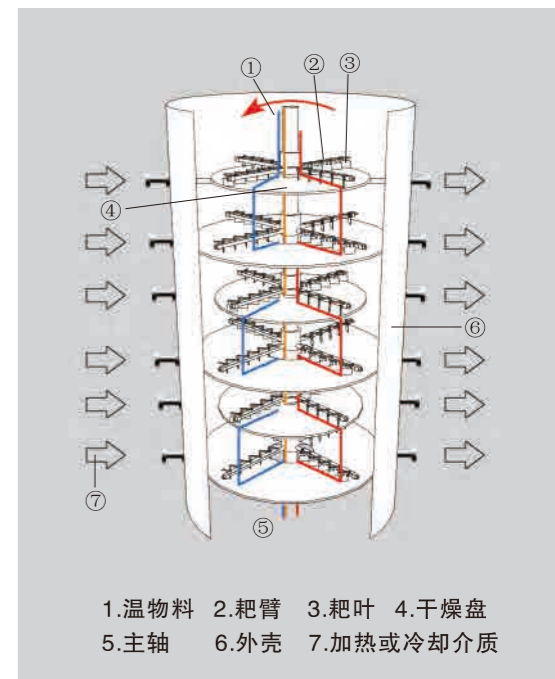

1.湿物料 2.耙臂 3.耙叶 4.干燥盘
5.主轴 6.外壳 7.加热或冷却介质

► 工艺流程 Technological process

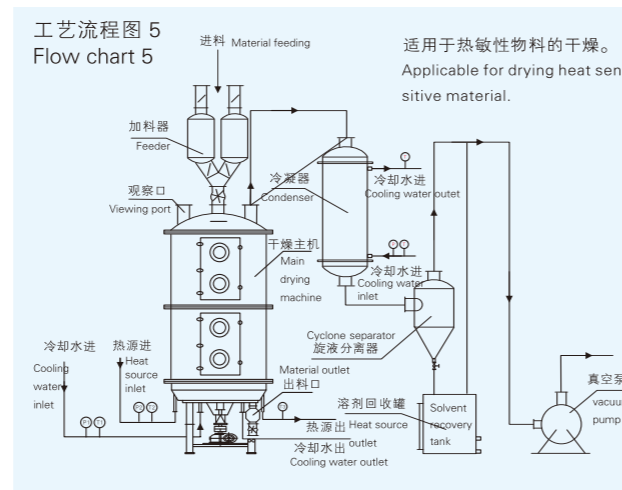
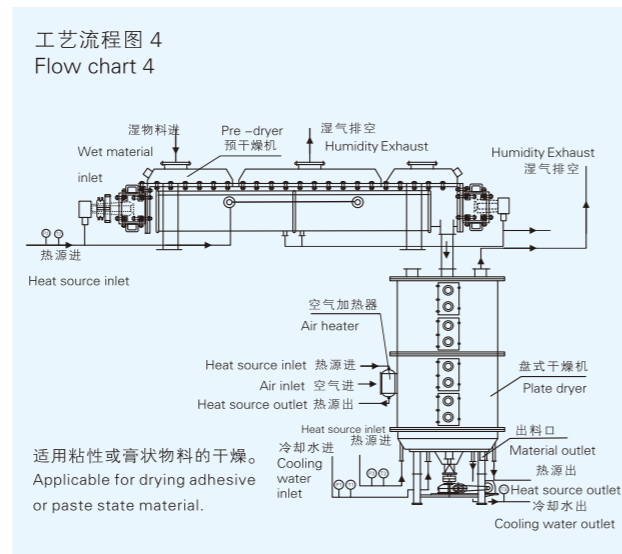
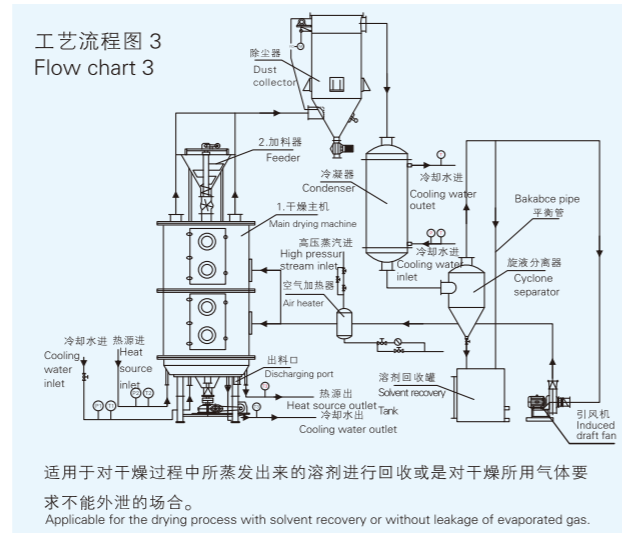
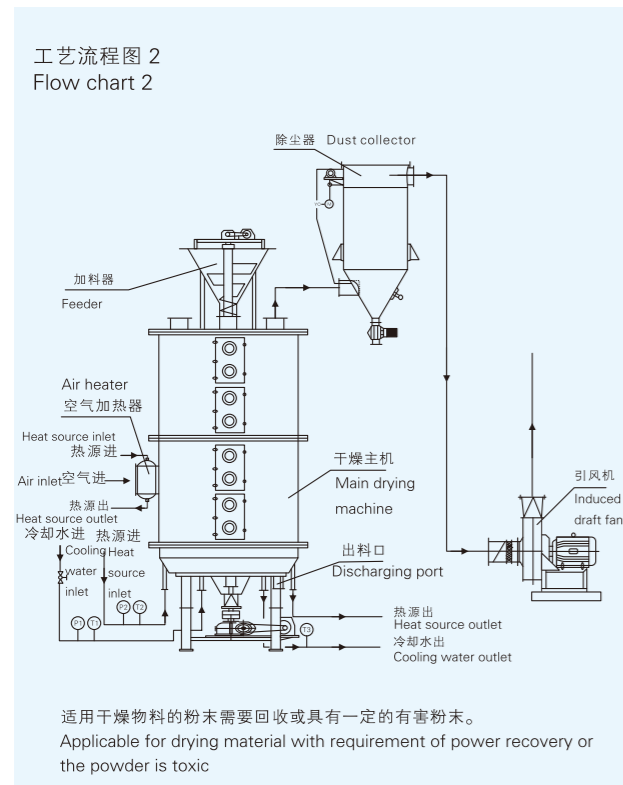
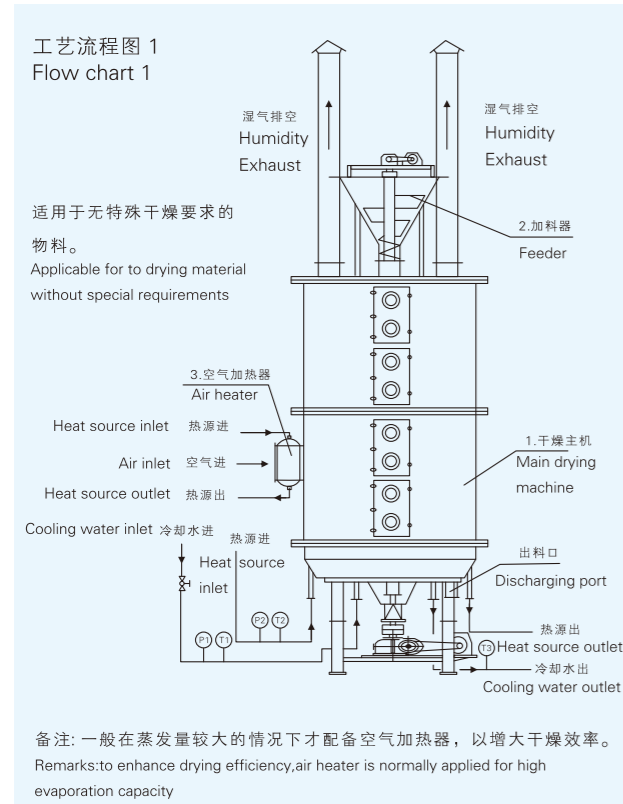

► 原理 Principle

湿物料自加料器连续地加到干燥器上部第一层干燥盘上,带有耙叶的耙臂作回转运动,使耙臂连续地翻抄物料。物料沿指数螺旋线流过干燥盘表面,在小干燥盘上的物料被移送到外缘,在大干燥盘上的物料向里移动并从中间落料口落入下一层小干燥盘中。大小干燥盘上下交替排列,物料得以连续地流过整个干燥器。中空的干燥盘内通入加热介质,加热介质形式有饱和蒸汽、热水和导热油,加热介质由干燥盘的一端进入,从另一端导出。已干物料从最后一层干燥盘落到壳体的底层,最后被耙叶移送到出料口排出。湿汽从物料逸出,由设在顶盖上的排湿口排出,真空型盘式干燥器的湿汽由设在顶盖上的真空泵口抽出。从底层排出的干物料可直接包装。通过配加翅片加热器、溶剂回收冷凝器、袋式除尘器、干料返混机构、引风机等辅机,可提高其干燥的生产能力,干燥膏糊状和热敏性物料,可方便地回收溶剂,并能进行热解和反应操作。



Wet materials are fed continuously to the first dryinglayer on the top of the dryer. They will be turned and stirred by rakes when the rake arm rotates and drop down to the outer edge of the large drying plate along the exponential helical line. On the small drying plate they will be moved to its outer edge and drop down to the outer edge of the large drying plate underneath, and will be moved inward and drop down from its central hole to the small drying plate on the next layer. Both small and large drying plates are arranged alternately so as materials can go through the whole dryer continuously. The heating media, which could be informs of saturated steam, hot water or heat conducting oil will be led into hollow drying plates from one end to the other end of the dryer. The dried materials will drop from the last layer of the drying plate to the bottom layer of the shell body, and will be moved by rakes to the dischargeport. The moisture escapes from materials and will be removed from the moist discharge port on the top cover, or sucked out by the vacuum pump on the top cover for vacuum-type plate dryer. The dried materials discharged from the bottom layer can be packed directly. The drying capability can be raised up if equipped with supplementary devices such as finned heater, condenser for solvent retrieval, bag dust remover, return and mix mechanism for dried materials and drawing fan etc. Solvent in those dried paste and heat sensitive materials can be easily retrieved, and thermal decomposition and reaction can be also carried out.

► 技术参数 Technical parameters

规格 Type	外径 Diamter (mm)	高度 High (mm)	干燥面积 Area of dry (m ²)	功率 Power (Kw)	规格 Type	外径 Diamter (mm)	高度 High (mm)	干燥面积 Area of dry (m ²)	功率 Power (Kw)		
1200/4	1850	2608	3.3	1.1	2200/18	2900	5782	55.4	5.5		
1200/6		3028	4.9		2200/20		6202	61.6			
1200/8		3448	6.6		2200/22		6622	67.7			
1200/10		3868	8.2		2200/24		7042	73.9			
1200/12		4288	9.9		2200/26		7462	80.0			
1500/6	2100	3022	8.0	2.2	3000/8		3800	4050		48	11
1500/8		3442	10.7		3000/10			4650		60	
1500/10		3862	13.4		3000/12			5250		72	
1500/12		4282	16.1		3000/14			5850		84	
1500/14		4702	18.8		3000/16			6450		96	
1500/16		5122	21.5		3000/18	7050		108			
2200/6	2900	3262	18.5	3.0	3000/20	3800		7650	120	13	
2200/8		3682	24.6		3000/22			8250	132		
2200/10		4102	30.8		3000/24			8850	144		
2200/12		4522	36.9		3000/26			9450	156		
2200/14		4942	43.1		3000/28		10050	168			
2200/16		5362	49.3		3000/30		10650	180			



概述 Descriptions

本公司在吸收国内外先进技术的基础上,进行改进、优化设计的楔型空心桨叶干燥机,可对膏状、颗粒状、粉状、浆状物料间接加热或冷却,可完成干燥、冷却、加热、灭菌、反应、低温煅烧等单元操作。设备中特殊的楔型搅拌传热桨叶,具有较高的传热效率和传热面自清洁功能。

This company by absorbing foreign advanced technology, based on to improve and optimize the design of the wedge-shaped hollow paddle dryer can treat paste, granular, powder, paste material through indirect heating or cooling, to achieve drying, cooling, heating, sterilization, reaction, low temperature calcination and other unit operations. Wedge-shaped mixing device in a special heat transfer blade, has a high heat transfer efficiency and heat transfer surface self-cleaning function.

原理 Principle

空心轴上密集排列着楔型中空桨叶,热介质经空心轴流经桨叶。单位有效容积内传热面积很大,热介质温度从 -40°C 到 320°C ,可以是水蒸汽,也可以是液体型:如热水、导热油等。间接传导加热,没有携带空气带走热量,热量均用来加热物料。热量损失仅为通过器体保温层向环境的散热。楔型桨叶传热面具有自清洁功能。物料颗粒与楔型面的相对运动产生洗刷作用,能够洗刷掉楔型面上附着物料,使运转中一直保持着清洁的传热面。桨叶干燥机的壳体为W型,壳体内一般安排二到四根空心搅拌轴。壳体有密封端盖与上盖,防止物料粉尘外泄及收集物料溶剂蒸汽。出口口处设置一挡板,保证料位高度,使传热面被物料覆盖而充分发挥作用。热介质通过旋转接头,流经壳体夹层及空心搅拌轴,空心搅拌轴依据热介质的类型而具有不同的内部结构,以保证最佳的传热效果。

Densely lined with wedge-shaped hollow shaft hollow blades, heat medium through the hollow axial flow through blades. Unit effective volume of a very large area of heat transfer, heat medium temperature from -40°C to 320°C , can be water vapor, may also be liquid-type: such as water, oil and so on. Indirect conduction heating, the air does not carry away the heat, the heat are used to heat materials. Only through the device body heat loss to the environment, heat insulation layer. Wedge-shaped blades with self-cleaning heat transfer surfaces. Wedge-shaped surface material particles and scrubbing effect relative movement, to wash away the wedge surface material attachments, so in operation have maintained a clean heat transfer surfaces. Blade dryer for the W-type shell, the shell of the general arrangements for 2-4 hollow stirring shaft. Shell with a sealed cover with the cover to prevent dust leakage and collection of materials, solvent vapor materials. Set out and exit pull a block, to ensure a high degree of material level, so that heat transfer surface is covered with fully materials. Heat medium through the rotary joint, passing through the shell jacket and the hollow stirring shaft, hollow shaft stirring according to the type of thermal media have different internal structures to ensure the best heat transfer.

结构示意图 Sketch of structure

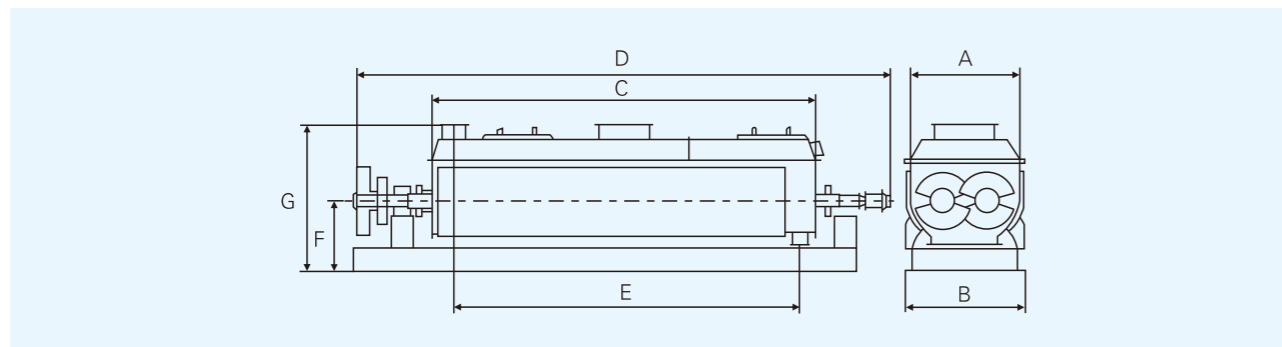

特点 Features

- ◇ 桨叶干燥机能耗低: 由于间接加热, 没有大量携带空气带走热量, 干燥器外壁又设置保温层, 对浆状物料, 蒸发1kg水仅需1.22kg水蒸汽。
- ◇ 桨叶干燥机系统造价低: 单位有效容积内拥有巨大的传热面, 就缩短了处理时间。设备尺寸变小, 就极大地减少了建筑面积及建筑空间。
- ◇ 处理物料范围广: 使用不同热介质, 既可处理热敏性物料, 又可处理需高温处理的物料。常用介质有: 水蒸汽、导热油、热水、冷却水等。既可连续操作也可间歇操作, 可在很多领域应用。
- ◇ 环境污染小: 不使用携带空气, 粉尘物料夹带很少。物料溶剂蒸发量很小, 便于处理。对有污染的物料或需回收溶剂的工况, 可采用闭路循环。
- ◇ 操作费用低: 该设备正常操作, 仅1-2人/天。低速搅拌及合理的结构。磨损量小, 维修费用很低。
- ◇ 操作稳定: 由于楔型桨叶特殊的压缩-膨胀搅拌作用, 使物料颗粒充分与传热面接触, 在轴向区内, 物料的温度、湿度、混合度梯度很小, 从而保证了工艺的稳定。

◇ Blade dryer energy consumption is low: as indirect heating, the air does not carry away a lot of heat insulation of dryer wall has, on the slurry material, evaporation of 1kg of water vapor only 1.22kg of steam.

◇ Blade dryer system costs low: within the effective volume of units have a large heat transfer surface, the reduced processing time, equipment size becomes smaller. Would greatly reduce the building area and building space.

◇ Dealing with a wide range of materials: using a different hot medium, able to deal with heat-sensitive materials can be heat-treated materials handling. Commonly used media are: water, steam, oil, hot water, cooling water. Continuous operation can also be intermittent operation can be applied in many fields.

◇ Environmental pollution: do not carry air, dust entrainment few materials. Solvent evaporation of material is very small, easy to handle. To have contaminated materials or be recycled solvent conditions, can be used closed circuit.

◇ Low operating cost: the equipment normal operation, 1-2 persons/day. Low speed and reasonable structure. Wear a small, very low maintenance costs.

◇ Operation stability: As the wedge-shaped blades of special compression - expansion of stirring, so that material particles sufficient surface contact with the heat transfer in the axial zone, the material temperature, humidity, mixed density gradient is very small, thus ensuring the process stability.

技术参数 Technical parameters

型号	KJG-2.7	KJG-9	KJG-13	KJG-18	KJG-24	KJG-29	KJG-36	KJG-41
传热面积 m^2 heat transfer area	2.7	9	13	18	24	29	36	41
有效容积 m^3 effective volume	0.06	0.32	0.59	1.09	1.53	1.85	2.42	2.8
转速范围r.p.m revolution	15-30	10-25	10-25	10-20	10-20	10-20	10-20	10-20
功率kw power	2.2	3.8	5.5	7.5	11	11	15	15
器体宽A mm width of dryer body	306	584	762	940	1118	1118	1296	1296
总宽B mm total width	736	841	1066	1320	1474	1474	1676	1676
器体长C mm length of dryer body	1956	2820	3048	3328	3454	4114	4115	4724
总长D mm total length	2972	4876	5486	5918	6147	6808	6960	7570
进出料距E mm Distance between feeding and discharging	1752	2540	2768	3048	3150	3810	3810	4420
中心高F mm height in center	380	380	534	610	762	762	915	915
总高G mm total height	762	838	1092	1270	1524	1524	1778	1778
进汽口N steam inlet	(2)3/4	(2)3/4	(2) 1	(2) 1	(2) 1	(2) 1	(2) 1	(2) 1
出水口O water outlet	(2)3/4	(2)3/4	(2) 1	(2) 1	(2) 1	(2) 1	(2) 1	(2) 1

型号	KJG-48	KJG-52	KJG-62	KJG-68	KJG-73	KJG-81	KJG-87	KJG-95	KJG-110
传热面积 m^2 heat transfer area	48	52	62	68	73	81	87	95	110
有效容积 m^3 effective volume	3.54	3.96	4.79	5.21	5.78	6.43	7.39	8.07	9.46
转速范围r.p.m revolution	10-20	10-20	10-20	10-20	5-15	5-15	5-15	5-15	5-10
功率kw power	30	30	45	45	55	55	75	75	95
器体宽A mm width of dryer body	1474	1474	1651	1652	1828	1828	2032	2032	2210
总宽B mm total width	1854	1854	2134	2134	2286	2286	2438	2438	2668
器体长C mm length of dryer body	4724	5258	5410	5842	5461	6020	5537	6124	6122
总长D mm total length	7772	8306	8865	9296	9119	9678	9119	9704	9880
进出料距E mm Distance between feeding and discharging	4420	4954	4953	5384	5004	5562	5080	5664	5664
中心高F mm height in center	1066	1066	1220	1220	1220	1220	1220	1220	1220
总高G mm total height	2032	2032	2362	2362	2464	2464	2566	2566	2668
进汽口N steam inlet	(2)11/2	(2)11/2	(2)11/2	(2)11/2	(2)11/2	(2)11/2	(2) 12	(2) 12	(2) 12
出水口O water outlet	(2)11/2	(2)11/2	(2)11/2	(2)11/2	(2)11/2	(2)11/2	(2) 12	(2) 12	(2) 12

注: 部分参数设计时视不同物料有所调整, 以设计为准。

► 应用 Applications



- ◇ 医药、食品、化工等行业进行以下物料干燥。
- ◇ 适用于浆状、膏糊状、粉状物料。
- ◇ 要求低温干燥的热敏性物料。
- ◇ 易氧化、易爆、强刺激、剧毒物料。
- ◇ 要求回收有机溶剂的物料。
- ◇ Such trades as the medicine , foo , chemical industr, etc. carry on the following supplies drily .
- ◇ Suitable for thick liquid form, the pastel of the lotion, powdery supplies.
- ◇ Temperature sensing supplies requiring the low temperature to be dry.
- ◇ Explosive, strong stimulating , drama poisonous substance material easy to oxidize.
- ◇ Demand to retrieve the supplies of the organic solvent.

► 原理 Principle



- ◇ 本干燥设备是在引进吸收国内耙式干燥技术的基础上改进的一种新颖卧式间歇式真空干燥设备，湿物料经传导蒸发，带有刮板搅拌器不断清除热面上的物料，并在容器内推移形成循环流，水份蒸发后由真空泵抽出。
- ◇ 本公司是国内耙式干燥机最专业的生产厂家。
- ◇ It is an innovation horizontal batch-type vacuum drier improved on the basis of introduced technology of other harrow driers. The moister of wet material will be evaporated by heat transmission. The stirrer with squeegee will remove material on hot surface and move in the container to form cycle flow. The evaporated moisture will be pumped by vacuum pump.
- ◇ Our company is specialized in producing Harrow Dryer.

► 技术参数 Technical parameters

项目Item	单位unit	机型 type									
		ZPG-500	ZPG-750	ZPG-1000	ZPG-1500	ZPG-2000	ZPG-3000	ZPG-4000	ZPG-5000	ZPG-6000	
名称Name											
工作容积 Working volume	L	300	450	600	900	1200	1800	2400	3000	3600	
加热面积 Heating area	m ²	3.2	4.4	5.1	6.3	8.1	10.6	12.3	14.2	16.5	
搅拌转速Stirring revolution	rpm	8~18									
功率Power	kw	4	5.5	5.5	7.5	7.5	11	15	18.5	22	
夹层设计压力Design pressure of jacket	MPa	0.3									
筒内压力Pressure in the cylinder	Mpa	-0.096~0.15									

注：水份蒸发量与物料的特性及热风进、出口温度有关。随着产品不断更新，有关参数变更，恕不预先通知。
Notes:the evaporated amount of water its related to the characteristics of raw materials and the temperature of air in and air out. With renew products unceasingly, the related parameters will be exchanged, it does not announce in advance, pardon !

► 特点 Features

- ◇ 本机采用大面积夹层加热方式，传热面大，热效率高。
- ◇ 本机设置搅拌，使物料在筒内形成连续循环状态，进一步提高了物料受热的均匀度。
- ◇ 本机设置搅拌，从而可顺利进行浆状、膏状、糊状物料干燥。
- ◇ 特殊出料口设计，使出料口更加密封和不容易积料，并且出料更方便。
- ◇ 密封分机封和填料密封两种，特殊的设计保证了密封性和使用寿命。
- ◇ 轴、耙叶的特殊加工，大大保证了轴的强度和同心度。
- ◇ 可根据用户要求在轴内通介质和增加振击装置。
- ◇ 根据不同的物料配置不同的过滤形式。
- ◇ 5m³ 以上耙干机夹套采用半管式夹套。

- ◇ This machine adopts large interlayer heating mode, the heat transfer surface is big, high thermal efficiency.
- ◇ The machine set, stir within the cylinder form a continuous loop of material status, further improving the heating uniformity of the material.
- ◇ Stir the machine Settings, and thus can be smoothly paste, paste, paste material drying.
- ◇ Special discharging mouth design, use and not easy to plot the more seal material, and discharging more convenient.
- ◇ Sealing machine seals and packing seal, special design to ensure the tightness and service life.
- ◇ Shaft, rake leaves special processing, greatly ensures the strength of the shaft and concentricity.
- ◇ According to user requirements in the shaft through media and increases vibration device.
- ◇ Depending on the different forms of filtering materials.
- ◇ The m3 jacketed rake dry machine USES half pipe jacketed.

► 结构示意图 Sketch of structure

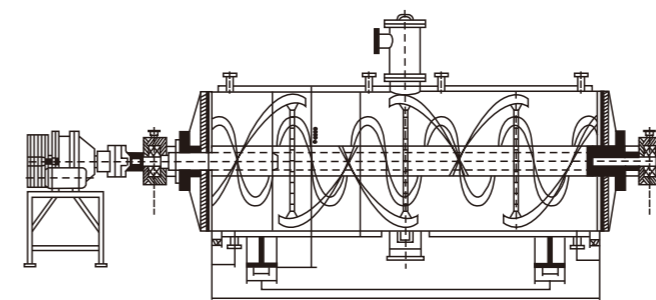
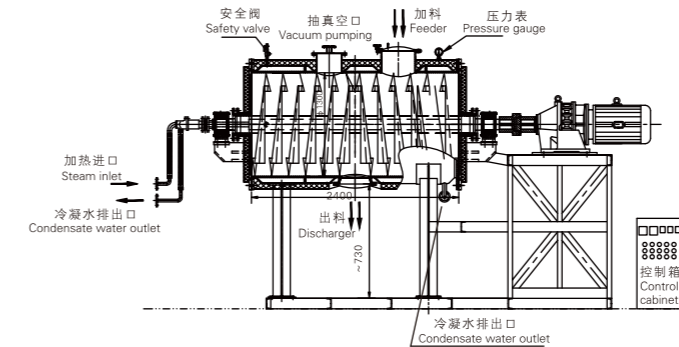

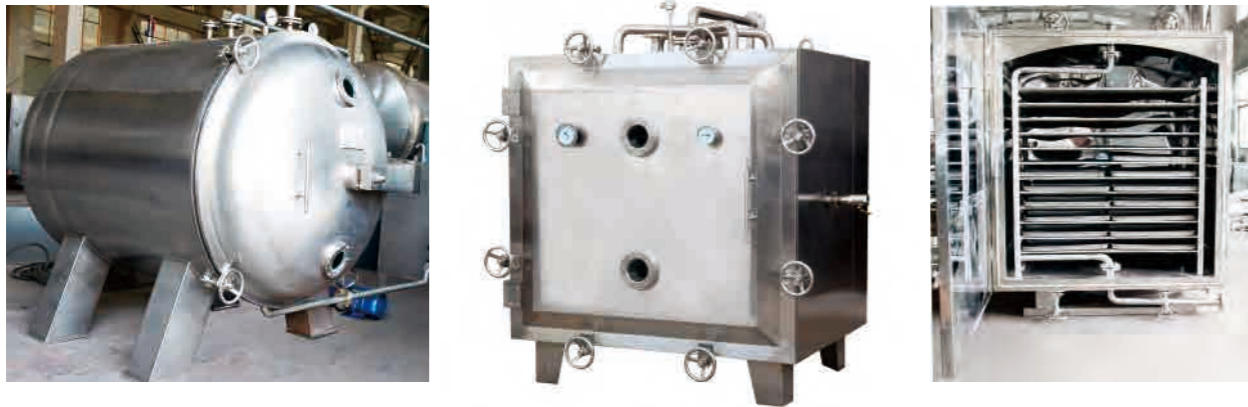

▶ 原理 Principle

所谓真空干燥，就是将干燥物料处在真空条件下，进行加热干燥，如果利用真空泵进行抽气抽湿，则加快了干燥速率。
注：如采用冷凝器，物料中的溶剂可通过冷凝器加以回收；如采用SK系列水环真空泵，可不用冷凝器，节省能源投资。

It is well known that vacuum drying is to put raw material under the state of vacuum for heating and drying. If use vacuum to pump air and humidity out, the dry speed will be faster.

Note: if use condenser, the solvent in raw material can be recovered. If the solvent is water, condenser might be canceled and the investment and every could be saved.

▶ 应用 Applications

适用于在高温下易分解，聚合和变质的热敏性物料的低温干燥；被广泛地采用在制药、化工、食品、电子等行业。

It is suitable for drying heat sensitive raw materials that can decompose or polymerize or deteriorate at high temperature. It is widely used in pharmaceutical, chemical, foodstuff and electronic industries.

▶ 技术参数 Technical parameters

名称 name	规格 specification	YZG-600	YZG-800	YZG-1000	YZG-1400	FZG-15
箱内尺寸 inside size of chamber		Φ600 × 976	Φ800 × 1274	Φ1000 × 1572	Φ1400 × 2054	1500 × 1220 × 1400
箱外尺寸 exterior size of chamber		1153 × 810 × 1020	1700 × 1045 × 1335	1740 × 1226 × 1358	2386 × 1657 × 1800	2060 × 1513 × 1924
烘架层数 layers of baking shelf		4	4	6	8	8
层间距离 interval of baking shelf		81	82	102	102	122
烘盘尺寸 size of baking disk		310 × 600 × 45	460 × 640 × 45	460 × 640 × 45	460 × 640 × 45	460 × 640 × 45
烘盘数 number of baking disk		4	8	12	32	32
烘架管内允压 permitted pressure inside the pipe of baking shelf (Mpa)		≤0.784	≤0.784	≤0.784	≤0.784	≤0.784
箱内温度 temperature inside chamber (°C)		30-150	30-150	30-150	30-150	30-150
箱内空载真空度 vacuum level inside chamber with out load (Mpa)				-0.1		
在30托真空，加热温度110°C时，水的气化率(kg/m ² ·h) when vacuum is 30 torr and the heating temperature is 110°C, vaporized rate of water				7.2		
不用冷凝器时，真空泵型号、功率 type and power of vacuum pump without condensate, (kw)		2X-15A 2KW	2X-30A 3KW	2X-30A 3KW	2X-70A 5.5KW	2X-70A 5.5KW
不用冷凝器时，真空泵型号、功率 type and power of vacuum pump without condensate, (kw)		SZ-0.5 1.5KW	SZ-1 2.2KW	SZ-1 2.2KW	SZ-2 4KW	SZ-2 4KW
干燥箱重量 weight of drying chamber (kg)		250	600	800	1400	2100

上述数据，仅供参考，如有特殊要求，本厂提供设计，咨询服务。
The above mentioned data is for reference only. If having special requirements, the factory can provide the service of consultation and design.

▶ 特点 Features

- ◇真空下物料溶液的沸点降低，使蒸发器的传热推动力增大，因此对一定的传热量可以节省蒸发器的传热面积。
- ◇蒸发操作的热源可采用低压蒸汽或废热蒸汽。
- ◇蒸发器热损失少。
- ◇在干燥前可进行消毒处理，干燥过程中无任何不纯物混入，符合GMP要求。
- ◇属于静态真空干燥器，故干燥物料的形体不会损坏。
- ◇Under the condition of vacuum, the boiling point of raw material will decrease and make the evaporation efficiency higher. Therefore for a certain amount of heat transfer, the conducting area of dryer can be saved.
- ◇The heat source for evaporation may be low pressure steam or surplus heat steam.
- ◇The heat loss is less.
- ◇Before drying, the treatment of disinfection may be carried out. During the period of drying, there is no impurity material mixed. It is in conformity with the requirement of GMP.
- ◇It belongs to static dryer. So the shape of raw material to be dried should not be destroyed.

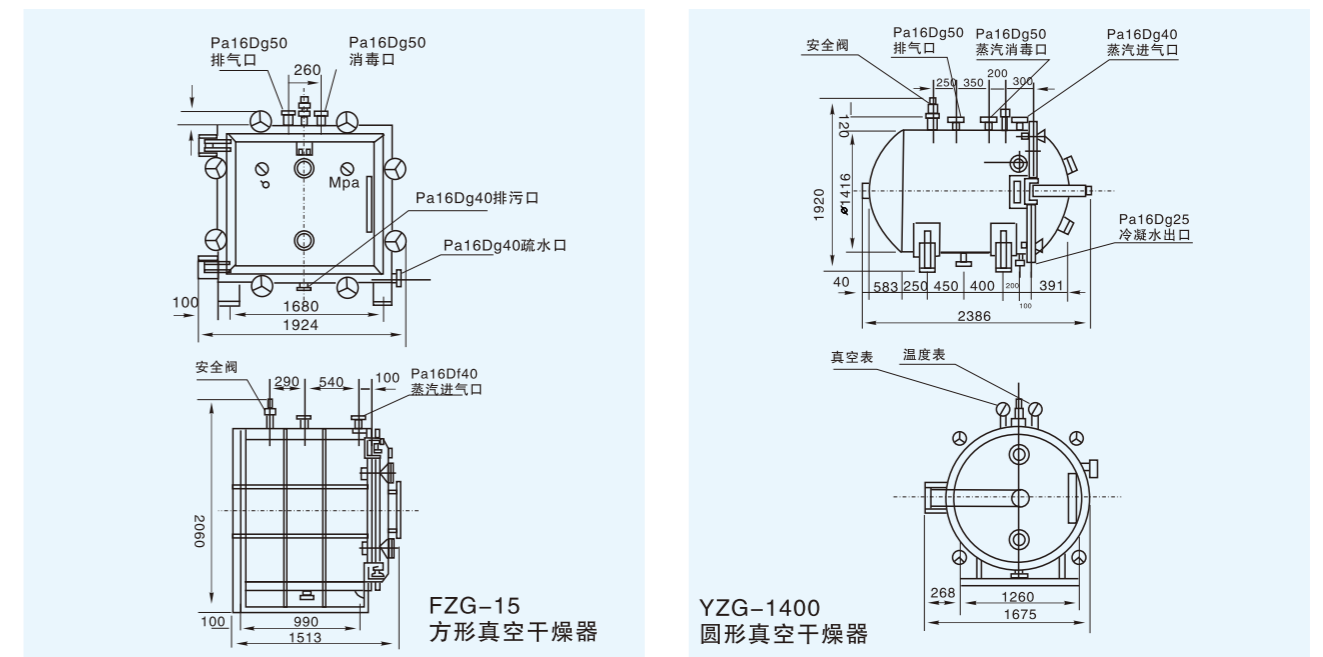

热水加热，溶剂回收
真空干燥系统图
System chart of heat with hot water,
solvent recover and vacuum drying

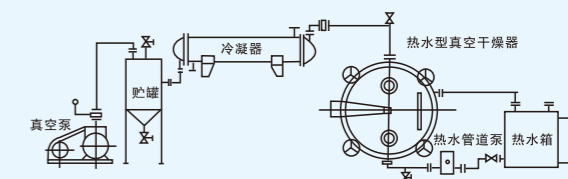

蒸汽加热，溶剂不回收
真空干燥系统图
System chart of heat with steam heat,
not solvent recover and vacuum drying

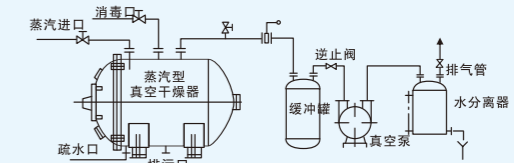

低温、快速、洁净

Low temperature, Rapid and Clean Vacuum Drier

► 概述 Descriptions

SZG双锥回转真空干燥机是我厂在结合国内同类产品技术所开发新一代干燥装置，SZG双锥回转真空干燥机具备皮带、链条两级弹性联结方式，因而设备运行平稳。特别设计的工装，充分体现了两支轴的良好同心，热媒及真空系统均采用可靠的美国技术的旋转接头。在此基础上，我们开发了SZG-A，它既可无级调速，又能进行恒温控制。

作为专业干燥设备制造厂，我们以每年百余台服务于用户，本厂产品从高温导热油为热媒介质、中温蒸汽及低温热水一应俱全。干燥粘性物料时，本厂将在罐内为您特别设计“抄板”机构或设置滚珠。

SZG Series Conical Vacuum Dryer is a new generation drying device developed by our factory on the basis of combining the technology of similar equipment. It has two connecting ways, i.e. belt or chain. Therefore it is stable in operation. The special design guarantees two shafts realize good concentricity. Heat medium and vacuum system all adapt reliable rotating connector with the technology from USA. On this basis, we also developed SZG-A. It can carry out stepless speed change and constant temperature control.

As a professional factory in drying industry, we supply hundred sets to the customers every year. As for heat medium, it may be thermal oil or steam or hot water. For drying the adhesive raw material, we have designed specially a stirring plate buffer for you.

◇ Heat source (for example, low pressure steam or thermal conduct oil) pass through the sealed jacket. The heat will be transmitted to raw material to be dried through inner shell;

◇ Under driving of power, the tank is rotated slowly and the raw material inside it is mixed continuously. The purpose of reinforced drying can be realized;

◇ The raw material exists is under vacuum. The drop of steam pressure makes the moisture (solvent) at the surface of raw material become saturation and will evaporate. The solvent will be discharged through vacuum pump and recovered in time. The inner moisture (solvent) of raw material will infiltrate, evaporate and discharge continuously. The three processes are carried out unceasingly and the purpose of drying can be realized within a short time.



► 原理 Principle

◇在密闭的夹层中通入热能源(如热水、低压、蒸汽或导热油)，热量经内壳传给被干燥物料。

◇在动力驱动下，罐体作缓慢旋转，罐内物料不断地混合，从而达到强化干燥的目的。

◇物料处于真空状态，蒸汽压下降使物料表面的水份(溶剂)达到饱和状态而蒸发了，并由真空泵及时排出回收。物料内部的水份(溶剂)不断的向表面渗透、蒸发、排出，三个过程不断进行，物料在很短时间达到干燥目的。

► 工艺流程 Technological process

推荐的工艺安置示范：溶剂回收工艺安置

example of recommended installation: installation of solvent recover.

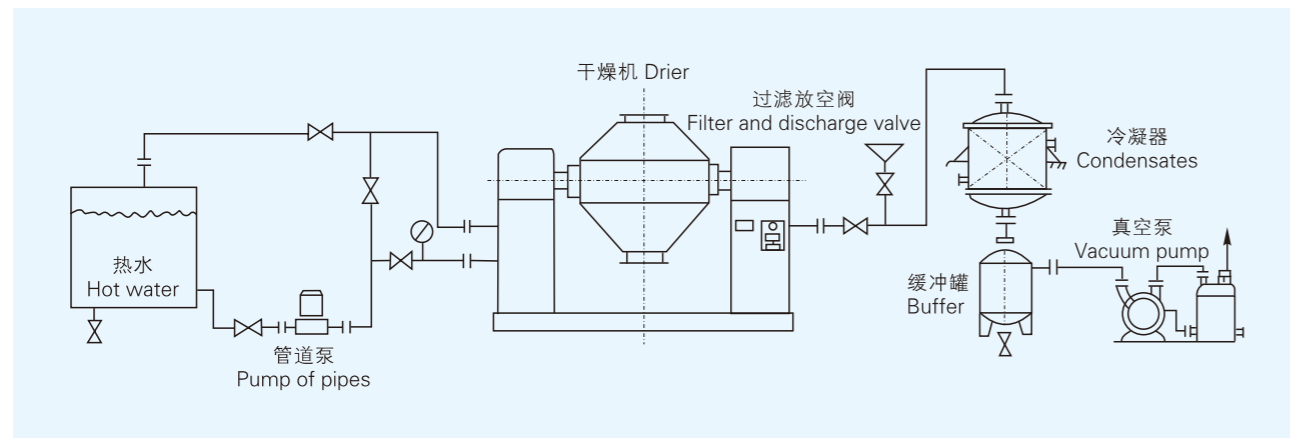

► 应用 Applications

适用化工、制药、食品等行业的粉状、粒状及纤维状物料的浓缩、混合、干燥及需低温干燥的物料(如生化制品等)，更适用于易氧化、易挥发、热敏性、强烈刺激、有毒性物料和不允许破坏结晶体的物料的干燥。

It is suitable for the raw materials that need to concentrate, mixed and dried at low temperature (for example, biochemistry) products in chemical, pharmaceutical and foodstuff industries. Particularly it is suitable for the raw materials that are easy to be oxidized, volatilized and have heat sensitivity and is toxic and not permitted to destroy its crystal in drying process.

► 特点 Features

◇油加热时，采用自动恒温控制，可以干燥生化制品和矿物原料，温度可在20~160℃之间。

◇热效率高，比一般烘箱提高2倍以上。

◇间接加热，物料不会被污染，符合"GMP"要求。设备维修操作简便，易清洗。

◇ When oil is used to heat, use automatic constant temperature control. It can be used for drying biology products and mine. Its temperature of operation can be adjusted form 20-160℃.

◇ Compared to ordinal dryer, its heat efficiency will be 2 times higher.

◇ The heat is indirect. So the raw material can not be polluted. It is in conformity with the requirement of GMP. It is easy in washing and maintenance.

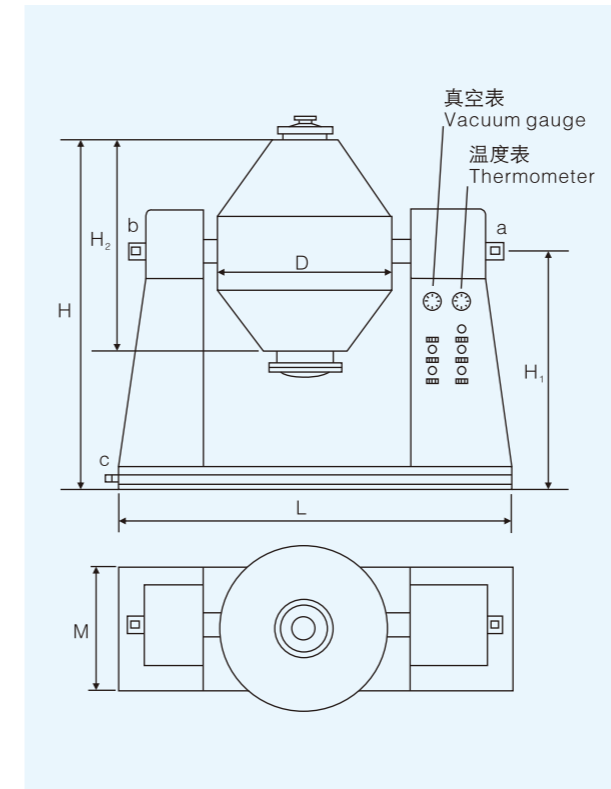

► 技术参数 Technical parameters

型号 Model	SZG-0.1	SZG-0.2	SZG-0.3	SZG-0.5	SZG-0.8	SZG-1	SZG-1.5	SZG-2	SZG-2.5	SZG-3	SZG-4.0	SZG-4.5	SZG-5.0
容积(升)Volume(L)	100L	200L	300L	500L	800L	1000L	1500L	2000L	2500L	3000L	4000L	4500L	5000L
参数 Tech parameters													
D	Φ800	Φ900	Φ1000	Φ1100	Φ1200	Φ1250	Φ1350	Φ1500	Φ1600	Φ1800	Φ1900	Φ1950	Φ2000
H	1640	1890	2000	2360	2500	2500	2600	2700	2850	3200	3850	3910	4225
H ₁	1080	1160	1320	1400	1500	1700	1762	1780	1810	2100	2350	2420	2510
H ₂	785	930	1126	1280	1543	1700	1750	1800	1870	2590	2430	2510	2580
L	1595	1790	2100	2390	2390	2600	3480	3600	3700	3800	4350	4450	4600
M	640	700	800	1000	1000	1150	1200	1200	1200	1500	2200	2350	2500
装料系数 Material feed weight	0.4-0.6												
最大装料量(kg) Max material feed weight	50	80	120	200	300	400	600	800	1000	1200	1600	1800	2000
接口 Interface	Dg50	Dg50	Dg50	Dg50	Dg50	Dg50	Dg50	Dg70	Dg70	Dg100	Dg100	Dg100	Dg100
(a)真空 c(冷凝水)	G3/4"	G3/4"	G3/4"	G3/4"	G3/4"	G1"	G1"	G1"	G1"	G1"	G1/2"	G1/2"	G1/2"
电机功率(kw) Motor Power	1.1	1.5	1.5	2.2	2.2	3	4	5.5	5.5	7.5	11	11	15
总重量(kg) Total weight	650	900	1200	1450	1700	2800	3300	3580	4250	5500	6800	7900	8800

备注：装料系数根据物料确定。本说明内容仅供参考；特殊要求，另行约定。

原型号 Original Model

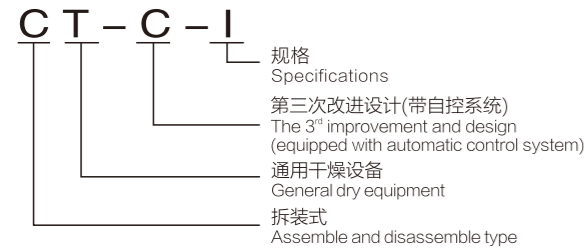

国家行业标准型号(The standard type made by the industry of the State)

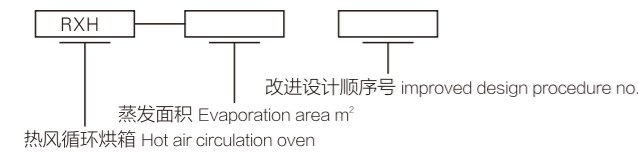

- 一、加热源有蒸汽、电、远红外、气电两用，供用户选择
- 二、使用温度：蒸汽加热50-130℃，最高140℃
- 三、用电、远红外温度50-300℃，可配套自控系统或电脑控制系统，供用户选择
- 四、常用蒸汽压力0.2-0.8mpa(2-8kg/cm2)
- 五、配用电加热按1型计算15kw，实用5-8kw/h
- 六、特殊要求在定货时表明
- 七、非标烘箱价格面议
- 八、使用温度大于140℃或小于60℃，要在定货时注明
- 九、本厂出厂的烘箱，烘盘尺寸统一，可以互换
- 十、烘盘尺寸：460X640X45mm

- 1.Options of heat source: steam, electricity, or far infrared, or both steam electricity.
- 2.Drying temperature: steam heating 50-130 °C , Max.140 °C .
- 3.Electricity and far infrared:50-300 °C .Automatic control system and computer control system on request.
- 4.Commonly used steam pressure 0.2-0.8Mpa(2-8 bar).
- 5.For CT-C-I, electric heated, rated power consumption:15Kw, real consumption : 5-8Kw.
- 6.The special requirements should be indicated at the time of order.
- 7.Please consult as for any special requirements.
- 8.For operation temperature of over 140 °C or less than 60 °C , please indicate when order.
- 9.The ovens and baking trays made by our factory are uniform in dimensions, and can be exchanged each other.
- 10.Baking plate dimensions:460*640*45mm

概述 Descriptions

CT-C型系列热风循环烘箱配有低噪音耐高温轴流风机和自动控温系统，整个循环系统全封闭，使烘箱的热效率从传统的烘房3-7%提高到目前的35-45%，最高热效率可达50%。CT-C型热风循环烘箱的设计成功，使我国的热风循环烘箱达到了国内外先进水平。为我国节约了大量能源，提高了企业的经济效益。1990年由国家医药管理局发布了行业标准，统一型号为RXH。

应用 Applications

适用于制药、化工、食品、农副产品、水产品、轻工、重工等行业物料及产品的加热固化、干燥脱水。如原料药、生药、中药饮片、浸膏、粉剂、颗粒、冲剂、水丸、包装瓶、颜料染料、脱水蔬菜、瓜果干、香肠、塑料树脂、电器元件、烘漆等。

CT-C series hot air circulation drying oven uses a low noise and high temperature proof axial flow blower and an automatic temperature control system. The whole circulation system is the fully enclosed to make that the heat efficiency of the drying oven increases from 3-7% of the traditional drying oven to 35-45% of the present one. The highest heat efficiency can reach 50%. The successful design of CT-C hot air circulation drying oven makes that the hot air circulation drying oven in our country catch the advanced level both at home and abroad. In order to save a large quantity of the energy in our country, in order to enhance the economic results of the enterprises, in 1990, the medicine management bureau of the State issued the industry standard and the uniform type is RXH.

This drying oven is suitable for the material and product hot solidification and dry de-watering in the pharmaceutical, chemical, food, farming, side-product, aquatic product, light industries, heavy industries and others industries. Such as: raw material medicine, crude drug, prepared herbal medicine of Chinese traditional medicine, plaster, powder, particle, drinking agent, pill, packing bottle, pigment, dyestuff, de-watering vegetable, dried fruit piece, sausage, plastics, resin, electric component, baking varnish and etc.

特点 Features

大部分热风在箱内循环，热效率高，节约能源。利用强制通风作用，箱内设有可调式分风板，物料干燥均匀，热源可采用蒸汽、热水、电、远红外，选择广泛。整机噪音小，运转平衡。温度自控，安装维修方便。适用范围广，可干燥各种物料，是通用干燥设备。

Most hot air is circulated in the oven. The Heat efficiency is high and the energy is saved. By using the forced ventilation function, there are adjustable air distribution plates inside the oven. The materials can be dried uniformly. The heating source might be steam, hot water, electricity and far infrared. With a wide selection. The whole machine is low in the noise. The operation is in balance. The temperature is controlled automatically. The installation and maintenance are easy. The application is wide. The machine can be used for drying various materials and is a versatile drying equipment.

结构示意图 Sketch of structure

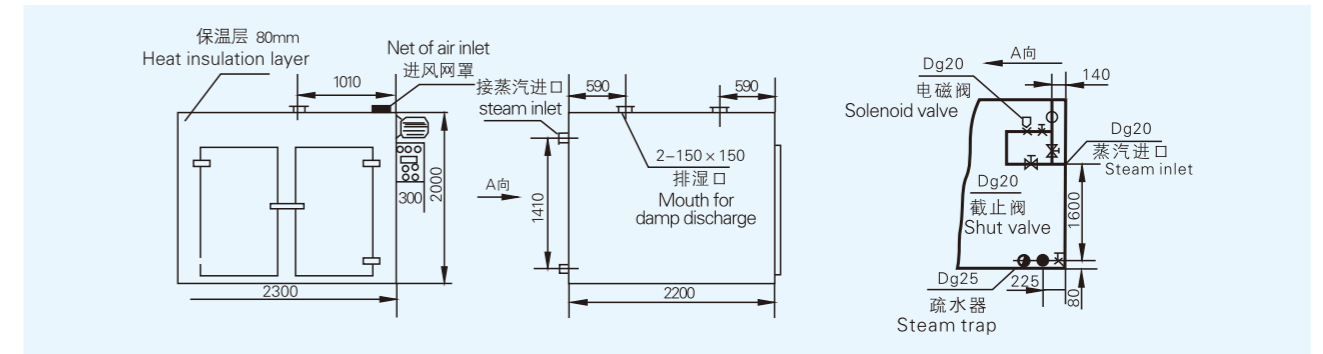

技术参数 Technical parameters

行业标准型号 Model of industrial standard	技术参数 Technical parameter 型号规格 Model specification	每次干燥量 Dry amount each time (kg)	配用功率 Equipped power (kW)	耗用蒸汽 Consumption of steam (kg/h)	散热面积 Area of radiation (m²)	风量 Amount of air (m³/h)	上下温差 temperature difference between up and low(°C)	配用烘盘 Amount of drying tray to be equipped	外型尺寸 Overall dimensions 宽×深×高 W×D×H(mm)	配套烘车 Equipped drying trolley
RXH-7-C	CT-C-O	50	0.55	10	10	3450	±2	24	1600×1200×2000	1
RXH-14-C	CT-C-I	100	0.55	18	20	3450	±2	48	2300×1200×2000	2
RXH-27-C	CT-C-II	200	1.1	36	40	6900	±2	96	2300×2200×2000	4
RXH-41-C	CT-C-III	300	1.65	54	80	10350	±2	144	3300×2200×2000	6
RXH-54-C	CT-C-IV	400	2.2	72	100	13800	±2	192	4460×2200×2000	8



一次成型打孔盘
Once shaping punched plate



手工井字网盘
Manual multi-square mesh plate



一次成型压制盘
Once shaping pressed plate



轴流风机 Axial fan

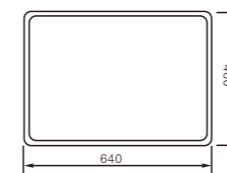

定型压制烘盘 材质：不锈钢、防锈铝合金
Shaped Pressed Baking-Plate
Material:stainless steel,rustproof aluminium alloy

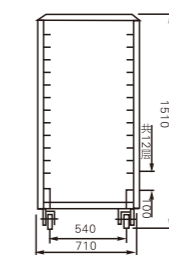

定型烘车 材质：不锈钢、A3钢
Shaped Baking Cart
Material:stainless steel,A3 steel

CT-C-O 型烘箱示意图 Sketch of model CT-C-O oven

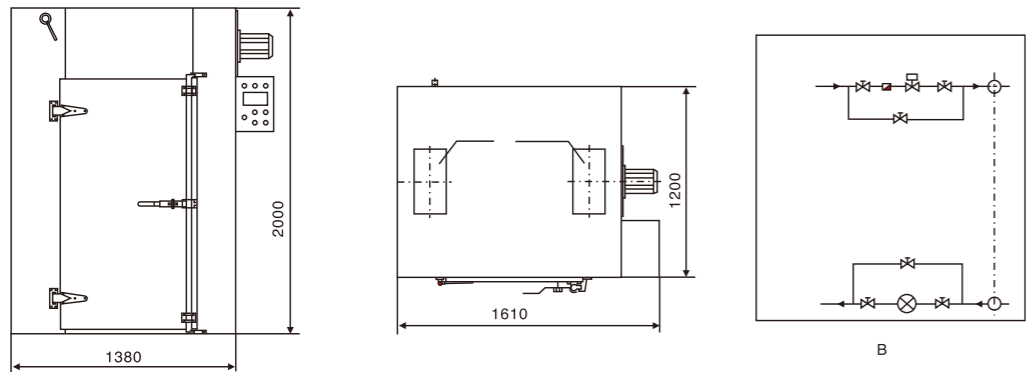

CT-C-I

CT-C-II

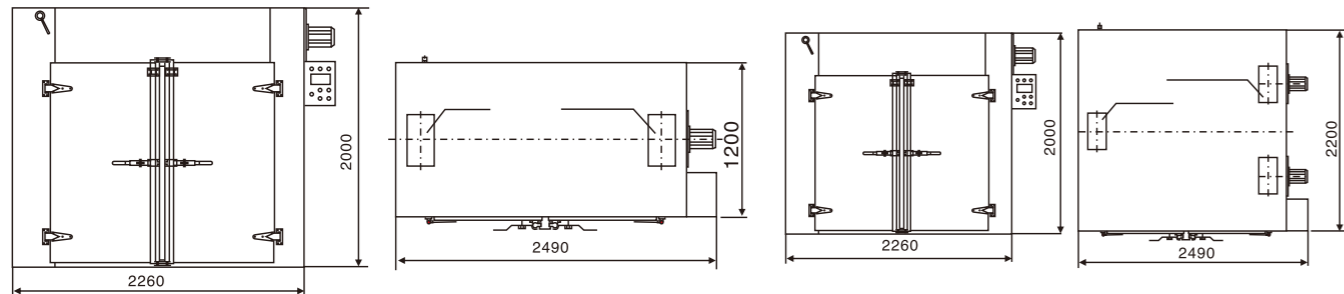

CT-C-III

CT-C-III A

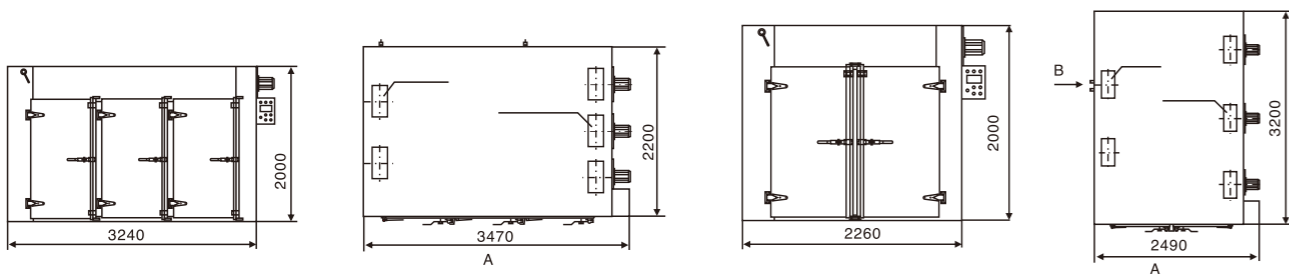

CT-C-IV

CT-C-IV A

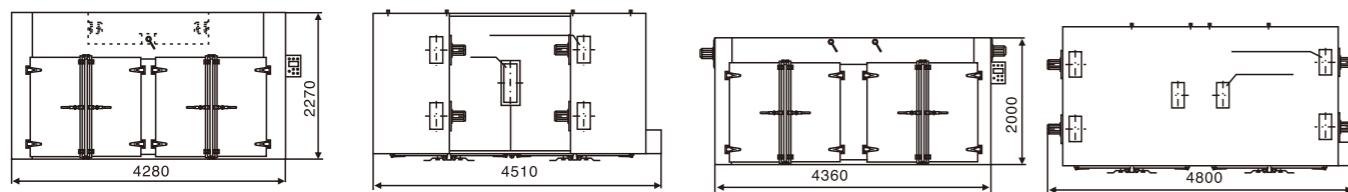

概述 Descriptions

SG 系列隧道式烘箱具有装料量大, 操作简单的特点。主要用于脱水蔬菜、果品, 如宁夏枸杞, 新疆红枣等农副产品的干燥; 及需要较长干燥时间的木件物料、陶瓷制品和各种散粒状物料的干燥和煅烧。

SG series of tunnel type oven has big loading capacity, simple operation. Is mainly suitable for dehydrated vegetables, fruits, such as Ningxia wolfberry, jujube in Xinjiang agricultural and sideline products dry; and the need to longer drying time of wood materials, ceramic products and various granular materials drying and calcination of the powder.

特点 Features

- ◇ 用户可根据物料特点选择纵向循环或横向循环的干燥方式, 来提高效率及产品质量;
- ◇ 可采用集中供热的方式, 这样更利于燃煤燃油燃气热风炉、导热油炉等热源连接, 方便用户生产使用;
- ◇ 根据用户需要, 可采用人工或机械方式进料和出料。

- ◇ 用户可根据物料特点选择纵向循环或横向循环的干燥方式, 来提高效率及产品质量;
- ◇ 可采用集中供热的方式, 这样更利于燃煤燃油燃气热风炉、导热油炉等热源连接, 方便用户生产使用;
- ◇ 根据用户需要, 可采用人工或机械方式进料和出料。

技术参数 Technical parameters

型号/项目 Model	每次装料量 (kg) Every time a charge	配用功率 (kw) With power	烘车数量 (辆) Drying car number	配用烘盘数 (个) With baking plate number	散热器 (m ²) The radiator
SG-11	1000	20.2	22	528	200
SG-16	1500	26.2	30	720	300
SG-22	2000	32.2	40	960	400
SG-30	2500	38.2	50	1200	500
SG-36	3000	38.2	60	1440	600

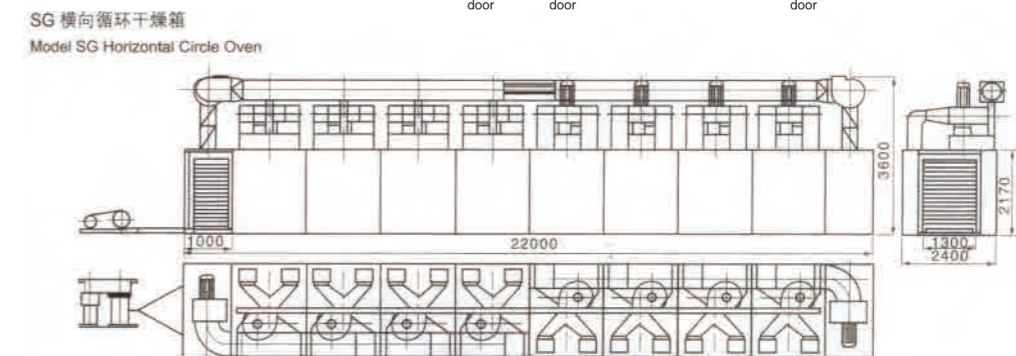
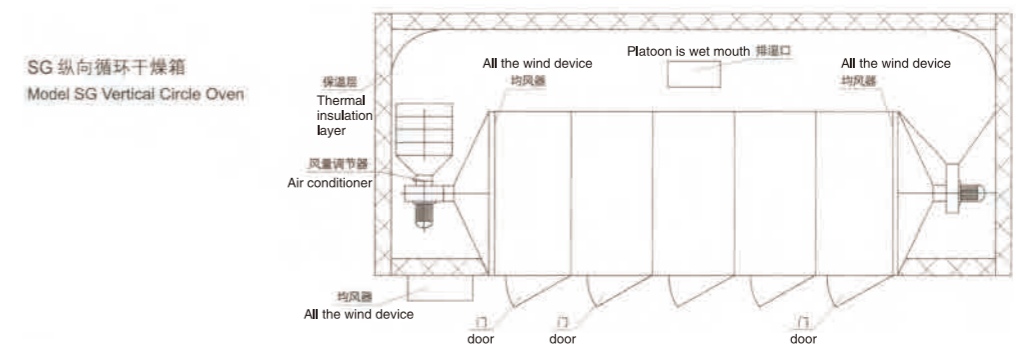

概述 Descriptions



DWT密封循环带式干燥机
DWT seal property circle type

原理 Principle

物料由加料器均匀地铺在网带上，网带一般采用12-60目不锈钢丝网，由传动装置拖动在干燥机内移动。干燥机由若干单元组成，每一单元热风独立循环，部分尾气由专门排湿风机排出，废气由调节阀控制，热气由下往上或由上往下穿过铺满物料的网带完成热量与质量传递的进程，带走物料水份。网带缓慢移动，运行速度可根据物料温度自由调节，干燥后的成品连续落入收料器中。上下循环单元根据用户需要可灵活配备，单元数量亦可根据需要选取。

The materials are uniformly distributed on the mesh-belt by the material feeder. The mesh-belt generally adopts 12-60 mesh stainless steel mesh and it is drawn by a transmission device and move inside the dryer. The dryer is composed of several sections. For each section, the hot air is circulated separately. Part of exhausted gas is exhausted by a special moisture exhaust blower. The waste gas is controlled by an adjustment valve. The hot air passes through the mesh-belt covered with bring water material away. The mesh-belt moves slowly, running speed can be freely adjusted according to the material property. The final products after the drying process will fall into the material collector continuously. The top and low circulation units can be freely equipped according to the user's requirements. The number of section might be selected according to the production demands.

应用 Applications

炒货、脱水蔬菜、颗粒饲料、味精、椰蓉、有机塑料、合成橡胶、丙烯酸纤维、药品、药材、小木制品、塑料制品、电子元器件老化、固化等。

Rosted seeds, De-watering vegetable, particle feed, gourmet powder, shredded coconut stuffing, organic color, compound rubber, acral fibre, medicine product, medicine material, small wooden product, plastic product, aging and solidification for the electronic component and device.



工艺流程 Technological process

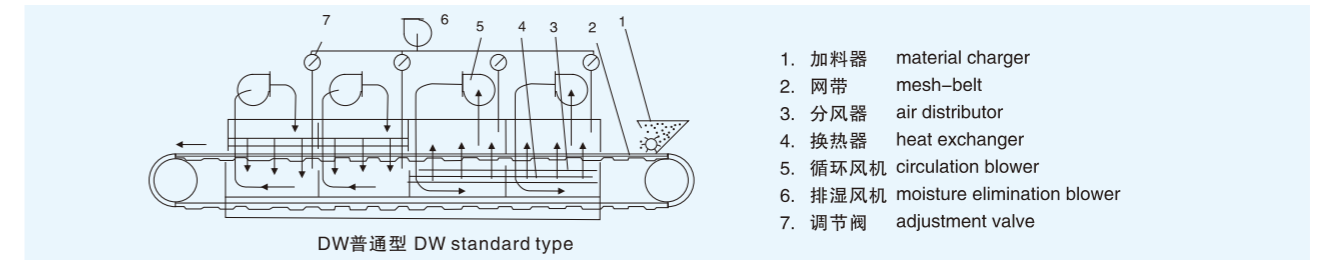

- 1. 加料器 material charger
- 2. 网带 mesh-belt
- 3. 分风器 air distributor
- 4. 换热器 heat exchanger
- 5. 循环风机 circulation blower
- 6. 排湿风机 moisture elimination blower
- 7. 调节阀 adjustment valve

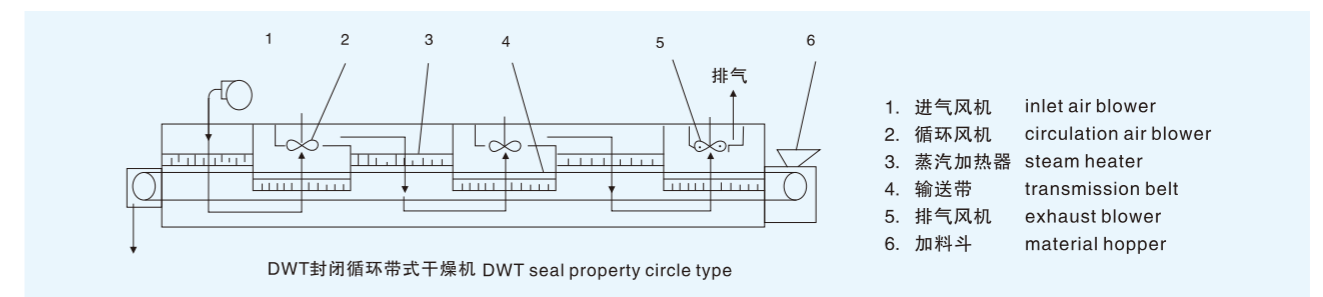

- 1. 进气风机 inlet air blower
- 2. 循环风机 circulation air blower
- 3. 蒸汽加热器 steam heater
- 4. 输送带 transmission belt
- 5. 排气风机 exhaust blower
- 6. 加料斗 material hopper

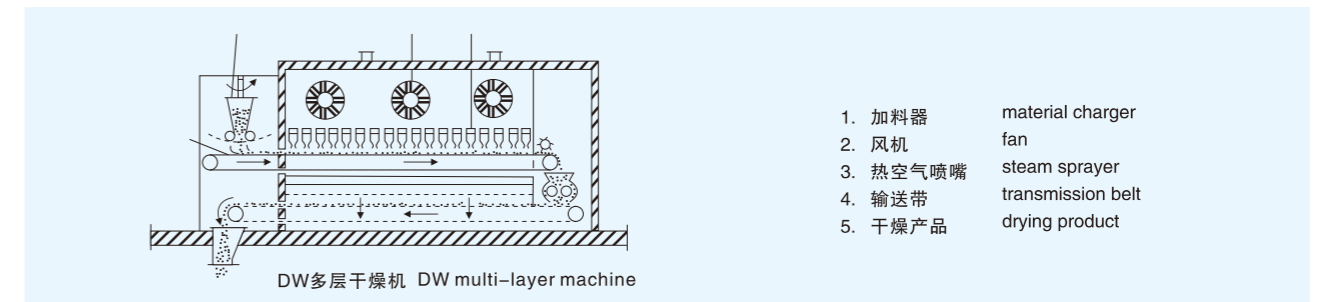

- 1. 加料器 material charger
- 2. 风机 fan
- 3. 热空气喷嘴 steam sprayer
- 4. 输送带 transmission belt
- 5. 干燥产品 drying product

技术参数 Technical parameters

型号 spec	单位 unit	DW-1.2-8	DW-1.2-10	DW-1.6-8	DW-1.6-10	DW-2-8	DW-2-10
单元数 unit number		4	6	4	6	4	6
带宽 belt width	m	1.2	1.2	1.6	1.6	2	2
干燥段长 drying section length	m	8	10	8	10	8	10
铺料厚thickness of the material	mm	10~80					
使用温度 temperature	℃	60~130					
蒸汽压力 steam pressure	Mpa	0.2~0.8					
蒸汽耗量 steam consumption	kg/h	150-300	150-375	150-375	170-740	170-740	225-600
干燥时间 drying time	h	0.2-1.2	0.25-1.5	0.2~1.2	0.25-1.5	0.2~1.2	0.25-1.5
干燥强度drying strength	kgH ₂ O/h	60-160	80-220	75-220	95-250	100-260	120-300
风机总功率 total power of the blower	kW	9.9	12.1	9.9	12.1	18.2	22.2
设备总功率 total power of the equipment	kW	11.4	13.6	11.4	13.6	19.7	23.7

注：1.带式干燥机一般都是结合某种物料的特殊性而设计的专业设备。2.其技术参数参照DW型参数表推出。

▶ 产品介绍 Product introduction

DW系列多层带式干燥机是成批生产用的连续式干燥设备，用于透气性较好的片状、条状、颗粒状物料的干燥，对于脱水蔬菜、催化剂、中药饮片等类含水率高、而物料温度不允许高的物料尤为合适；该系列干燥机具有干燥速度快、蒸发强度高、产品质量好的优点，对脱水滤饼类的膏状物料，需经造粒或制成条状后方可干燥。

The belt drier is a continuous drying equipment in batch production. It is suitable for drying the raw materials that is in the shape of piece, strip or granule and is good in permeability. Particularly it is suitable for such raw materials that contain high moisture and are not permitted high temperature for example, dehydrated vegetable, catalyst, drinking tablet of Chinese traditional medicine. Its features are fast in drying speed, strong in vaporization, good in quality of products.

Typical products Dehydrated vegetable, granule feed, monosodium glutamate, check extraction, organic pigment, synthetic rubber, propylene fiber, medicine, medical material, small wooden products, plastic products, aging or solidifying for electronic elements. For pasted raw material such as filter cake, it can be dried after shaped through granulator or extruder.



▶ 概述 Descriptions

DW系列多层带式干燥机适用于大规模生产干燥速率较低的难干燥物料，设备结构紧凑，占地面积小，操作简单，维护方便、运行稳定。可根据物料的干燥特性设计成不同的热风循环干燥形式，是热风循环烘箱的延伸和改进，广泛应用于冶金助剂、化工、食品、包装等领域。随着企业技术进步，产品技术含量的提高，多层带式干燥机已具备满足大生产、多元化、集中控制、连续生产的能力。具有高效、节能、易于管理的优势。

DW series many layers belt dryer is used in the material hard to dry and low dry speed. The equipment structure is compact. It covers small area with easy operation, convenient maintain and steady running. The equipment extend and promote the heat wind circle oven which design the dryness process with different heat wind circle as per the dryness characteristics of materials. It is widely used in chemical, metallurgy industry, food, packaging. The dryer has lots of superiorities as high efficiency, saving energy, easy management, larger output, constant product and varied ability.



▶ 结构示意图 Sketch of structure

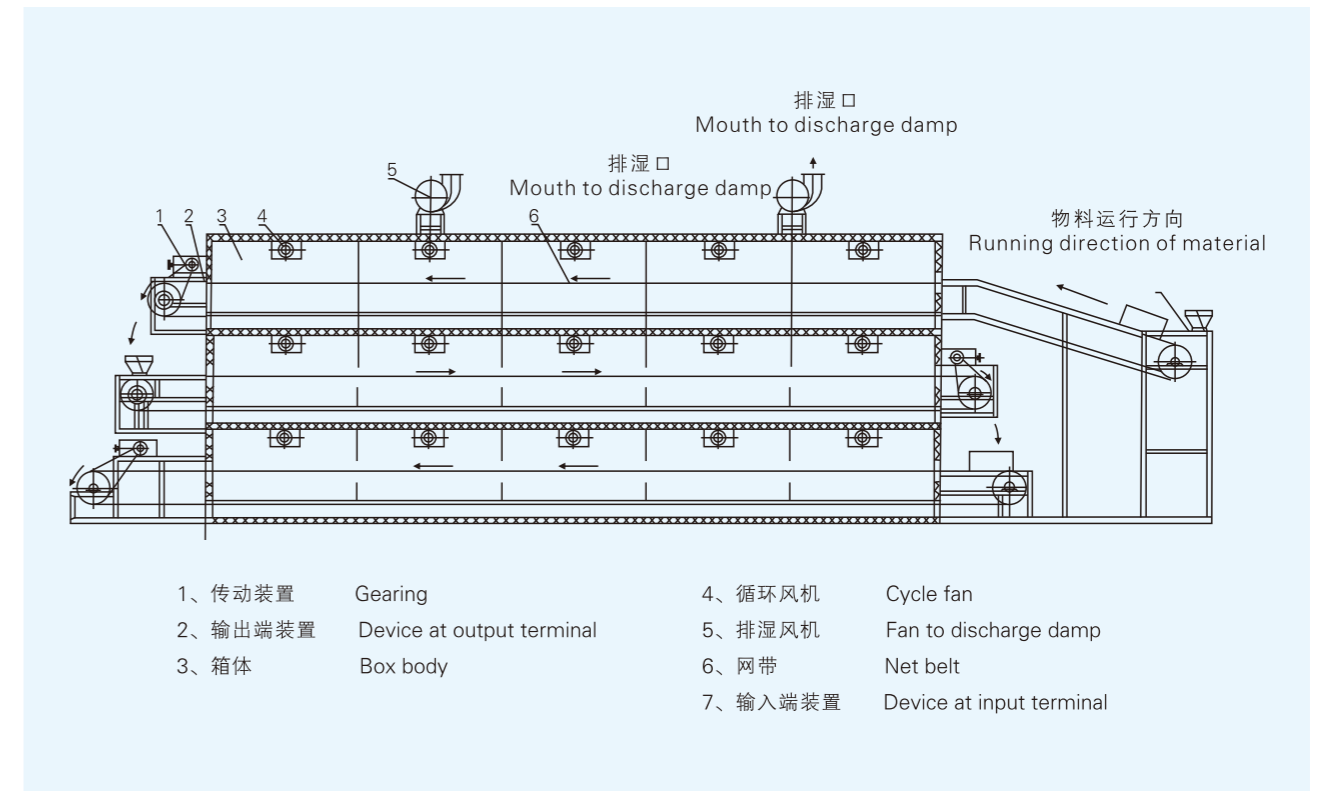

▶ 技术参数 Technical parameters

型号 Spec	单位 unit	DW ₃ -1.2-8	DW ₃ -1.2-10	DW ₃ -1.6-8	DW ₃ -1.6-10	DW ₃ -2-8	DW ₃ -2-10
单元数 Unit number		4 × 3	5 × 3	4 × 3	5 × 3	4 × 3	5 × 3
干燥段长 Drying section length	m	24	30	24	30	24	30
铺料厚 Thickness of the material	mm	10-80					
使用温度 Temperature	°C	50 ~ 140					
蒸汽压力 Steam pressure	Mpa	0.2 ~ 0.8					
蒸汽耗量 Steam consumption	kg/h	360-600	420-720	450-840	480-960	480-960	630-1350
换热面积 Area of heat exchange	m ²	816	1020	1056	1320	1344	1680
干燥强度 Drying strength	kgH ₂ O/h	150-450	220-550	240-600	280-750	280-750	350-900
内机总功率 Power equipment inside	kW	30.8	37.4	42	51	56	68
外机总功率 Power equipment outside	kW	35.3	41.9	46.5	55.5	60.5	72.5
外形尺寸 Overall dimensions	m	9.77 × 2.2 × 4.5	11.77 × 2.2 × 4.5	9.77 × 2.6 × 4.5	11.77 × 2.6 × 4.7	9.77 × 3.06 × 4.9	11.77 × 3.06 × 4.9
总重 Weight	Kg	4800 × 3	5780 × 3	5400 × 3	6550 × 3	6350 × 3	7800 × 3

注：对于干燥温度在250-350℃时，本公司可根据实际物料进行特殊设计。

概述 Descriptions

DWT脱水干燥机是在传统网带式干燥机基础上研究开发的专用型设备，具有较强的针对性，实用性，能源效率高，广泛用于各类地区性和季节性蔬菜、果品的脱水干燥，如：蒜片、南瓜、魔芋、白萝卜、山药、竹笋等，已拥有用户50多家，在线设备80多台套，是国内最富经验的蔬菜干燥设备生产企业，工厂科技人员长期跟踪服务于这些用户，深入用户进行调试研究，得到第一手实践资料并结合国外先进技术，不断改进完善设备，到目前为止，已开发了对第三代DWT系列蔬菜脱水干燥机，我们在为用户生产制作设备时，根据所需干燥产品的特性，用户工艺要求，结合十几年来积累的经验，为用户设计制作出最适用，品质最佳的蔬菜干燥设备。

DWT Series Dryer for Vegetable Dehydration is special equipment researched and developed on the basis of traditional net belt dryer, it has stronger pertinency, practicability and high efficiency of energy. It is wide used for all kinds of vegetables dehydration such as garlic, cushaw, giantarum, white turnip, yam, bamboo shoot, etc at different region and season, our factory has more 50 of customers and more 80 of production line in operation. Our factory is an enterprise with the richest experience to manufacture dryer for vegetables dehydration. The technicians of our factory carry out after sales service for customers all the year round and help customers to debug and produce. There fore they have got first-hand practical data and combined domestic and abroad advanced technology and improved and perfected the equipment. Till the third generation. DWT series dryer for vegetables dehydration has been developed. we are making advanced productive equipment for customers. according to the characteristics of raw materials too be dried and the process requirements of customers and combined the accumulated experience for more ten years, we have made the most suitable and the dryer for vegetables dehydration too supply customers.

应用 Applications

◇ 能满足根、茎、叶类条状、块状、片状、大颗粒等蔬菜物料的干燥和大批量连续生产，同时能最大限度的保留产品的营养成分及颜色等。

◇ 干燥的典型物料有：蒜片、南瓜、胡萝卜、魔芋、山药、竹笋、辣根、洋葱、苹果等。

◇ It can meet to dry different vegetables such as, root, halm, leaf, tuberos rot, big granule and produce in batch. Meanwhile it can maintain content of nutrition, color, etc of vegetable in most extent.

◇ The type raw materials are garlic, cushaw, giantarum, white turnip, yam, bamboo shoot, capsicum, onion, apple, etc.



特点 Features

◇ 干燥面积、风压、风量、干燥温度、网带速度均可调节，以适应蔬菜的特性及品质要求。

◇ 可根据蔬菜的不同特点，采用不同的工艺流程及添加配套必要的辅助设备。

◇ Its dry area, air pressure, air amount, dry temperature and speed of net belt can be adjusted in order to suitable for different characteristics of vegetable and the requirement of quality.

◇ It can adapt different process and equip necessary auxiliary equipment in accordance with different characteristics of vegetable.



原理 Principle

◇ 蔬菜脱水干燥机分别有加料器、干燥床、热交换器及排湿风机等主要部件组成。

◇ 干燥机工作时，冷空气通过热交换器进行加热，采用科学合理循环方式，使热空气穿流通过床面上的被干燥物料进行均匀的热质交换，机体各单元内热气流在循环风机的作用下进行热风循环，最后排出低温高湿度的空气，平稳高效地完成整个干燥过程。

◇ The dryer for vegetable dehydration consists of feeder, drying bed, heat exchanger, damp exhaust fan, etc.

◇ When operation, air will be entered into dryer and heated through heat exchanger. Being adapted scientific and reasonable cycle method, the hot air will pas through raw materials to be dried on the bed and carry out uniform heat exchange. Under the action of cycle fan, the hot air stream inside each unit of the dryer will carry out hot air cycle. Final air with low temperature and high damp will be out. The whole drying process with stably and high effect will be finished.

工艺流程 Technological process

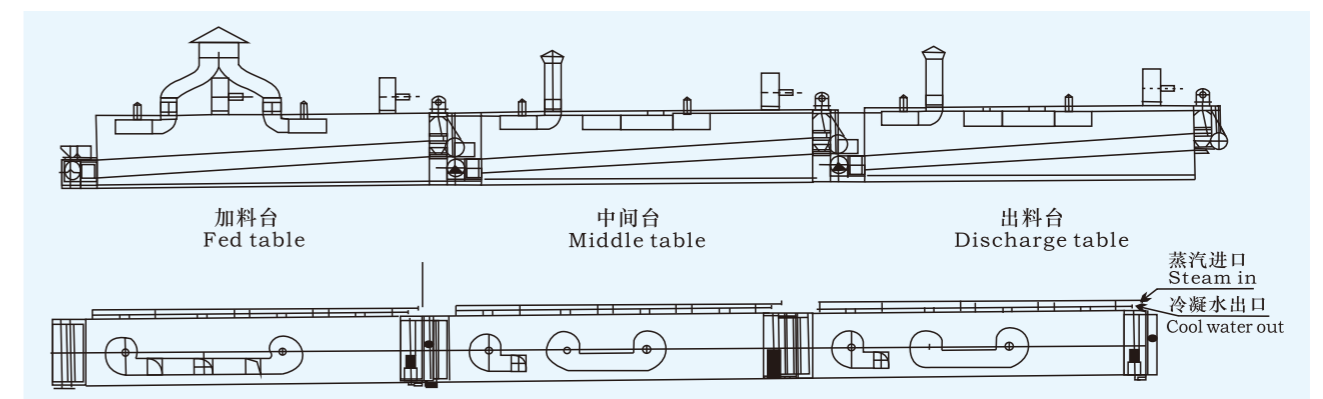

技术参数 Technical parameters

型号Type	DWT1.6-I (加料台) fed table	DWT1.6-II (中间台) middle table	DWT1.6-III (出料台) discharge table	DWT2-I (加料台) fed table	DWT2-II (中间台) middle table	DWT2-III (出料台) discharge table
网带宽Belt width (mm)	1.6	1.6	1.6	2	2	2
干燥段长Drying section length (m)	10	10	8	10	10	8
铺料厚度 Thickness of the material to be covered(mm)	≤100	≤100	≤100	≤100	≤100	≤100
使用温度Temperature(°C)	50-150°C	50-150°C	50-150°C	50-150°C	50-150°C	50-150°C
换热面积Areae of heat conduction(m²)	525	398	262.5	656	497	327.5
蒸汽压力Steam pressure(MPa)	0.2-0.8	0.2-0.8	0.2-0.8	0.2-0.8	0.2-0.8	0.2-0.8
干燥时间Drying time(h)	0.2-1.2	0.2-1.2	0.2-1.2	0.2-1.2	0.2-1.2	0.2-1.2
装机功率 Power(kw)	15.75	12.75	9.55	20.75	16.75	12.55
外形尺寸Overall Dim.(m)	12 × 1.81 × 1.9	12 × 1.81 × 1.9	10 × 1.81 × 1.9	12 × 2.4 × 1.92	12 × 2.4 × 1.92	10 × 2.4 × 1.92

应用 Applications

- ◇ 制药工业中的造粒：片剂颗粒、冲剂颗粒、胶囊剂颗粒。
- ◇ 食品工业的造粒：可可、咖啡、奶粉、颗粒果汁、调味品等。
- ◇ 其他行业的造粒：农药、饲料、化肥、颜料、染料化工等。
- ◇ 粉状或颗粒状湿物料的干燥。
- ◇ 包衣：颗粒、丸剂保护层、备色、缓释、薄膜、肠溶包衣等。
- ◇ Phamaceutical industry: tablet, capsule, low sugar or no sugar granule of chinese medicine.
- ◇ Foodstuff: cocoa, coffee, milkpowder, juice of granulate, flavoring and so on.
- ◇ Other industries: pesticide, feed chemical fertilizer, pigment, dyestuff and so on.
- ◇ Pharmaceutical industry: power or granule material.
- ◇ Coating: Granule, protecting coat of pellet, spare color, slow release film, bowel-dissolve coating, etc.



原理 Principle

物料粉末粒子,在原料容器(流化床)中呈环形流化状态,受到经过净化后的加热空气预热和混合,将粘合剂溶液雾化喷入,使若干粒子聚集成含有粘合剂的团粒,由于热空气对物料的不断干燥,使团粒中水分蒸发,粘合剂凝固,此过程不断重复进行,形成理想的、均匀的多微孔颗粒。

The powder granule in the container (fluidization) appear in the state of fluidization. It is preheated and mixed with chen and heated air. At the same time the solution of adhesive solvent is fogged and sprayed into the container. It makes the some particles become granulating that contains adhesive. Being of unceasing dry through hot air, the moisture in the granulation is evaporated and the adhesive is solidification. The process is carried out continuously. Finally it forms ideal, uniform and Porous granules.

特点 Features

- ◇ 通过粉体造粒,改善流动性,减少粉尘飞扬;
- ◇ 通过粉体造粒改善其溶解性能;
- ◇ 混合、制粒、干燥在一机内完成一步法制粒;
- ◇ 采用抗静电滤布,设备操作安全;
- ◇ 设置压力泄放孔,一旦发生爆炸,设备人员不受伤害;
- ◇ 设备无死角,装卸料轻便快速,冲洗干净,满足GMP规范。

- ◇ Because of powder Granulation, the fluidity is improved and the dust is reduced;
- ◇ Because of powder Granulation, its solving property is improved;
- ◇ The mixing, Granulation and drying can be completed in one step inside the machine;
- ◇ The operation of equipment is safe because the anti static filtering cloth is adapted;
- ◇ The operating personnel can not be damaged if explosion take place because there is releasing hole;
- ◇ The equipment has no dead corner. Therefore the loading and unloading are quick and light and clean. It can meet the requirements of GMP.

工艺流程 Technological process

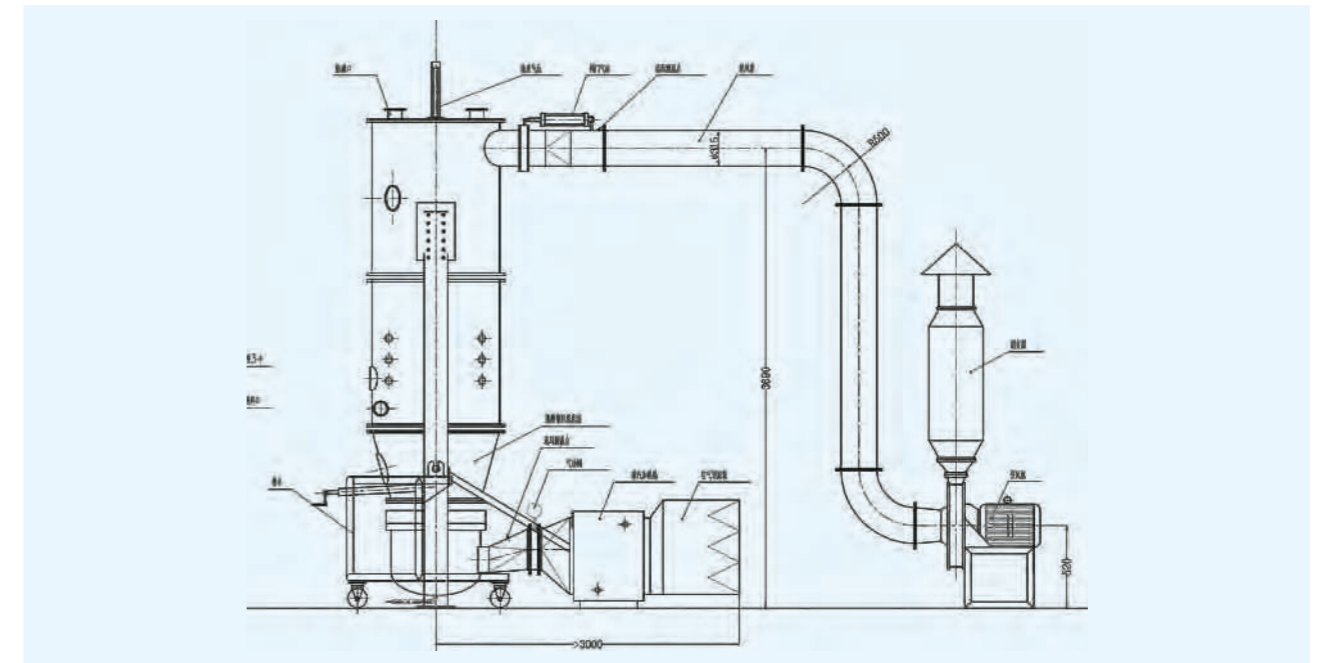

技术参数 Technical parameters

项目Item	单位Unit	机型 type										
		3	5	15	30	60	120	200	300	500	800-1000	
原料容器 Container	容量Volume	L	12	22	45	100	220	420	670	1000	1500	
	直径Diameter	mm	300	400	550	700	1000	1200	1400	1600	1800	
生产能力 Capability	最小Min	Kg	1.5	4	10	15	30	80	100	150	250	
	最大Max	Kg	4.5	6	20	45	90	160	300	450	750	
风机Fan	风量Capacity	m³/h	1000	1200	1400	1800	3000	4500	6000	7000	8000	
	风压Pressure	mmH₂O	375	375	480	480	950	950	950	950	950	
	功率Power	kw	3	4	5.5	7.5	11	18.5	22	30	45	
蒸汽消耗量Steam expenditure	Kg/h	15	23	42	70	141	211	282	366	451	按用户 要求 设计 By client	
压缩空气耗量Compressed air expenditure	m³/min	0.9	0.9	0.9	0.9	1.0	1.0	1.1	1.5	1.5		
主机重量Weight of the main body	Kg	500	700	900	1000	1100	1300	1500	1800	2000		
蒸汽压力Steam pressure	Mpa	0.3~0.6										
温度Temperature	°C	室温~120°C范围内可调节 (adjustable at the range from room temperature to 120°C)										
作业时间Working time	min	随物料特性而定45~90 (decided in accordance with the proplerties of raw materials)										
物料收得率Field	%	≥99										
噪声Noise	dB(A)	风机与主机隔离安装, 噪声≤75dB(A)(When installation, main machine is separated from fan)										
主机外型尺寸Size(L×W×H)	m	1.0×0.6 ×2.1	1.2×0.7 ×2.1	1.25×0.9 ×2.5	1.6×1.1 ×2.5	1.85×1.4 ×3	2.2×1.65 ×3.3	2.34×1.7 ×3.8	2.8×2.0 ×4.0	3×2.25 ×4.4		

► 概述 Descriptions

FLP多功能制粒包衣机是集喷雾干燥—制粒—离心制丸—流化包衣干燥于一体的多功能设备。该机兼容多种工艺操作。特别适用于医药、食品、化工等行业多品种、多剂型制粒、制丸及包衣。

FLP Granulator/Coater/Pelleter is multi-function equipment integrated spray drying—granulating—centrifugal spray coating—fluid coating—drying in one body. The machine combines various process operations. Particularly it is suitable for granulating, pelleting and coating of various varieties in pharmaceutical industry, foodstuff industry and chemical industry.etc.

► 特点 Features

- ◇ 集制粒、制丸、包衣多种功能于一体。
- ◇ 粉体物料制粒。
- ◇ 粉体物料包衣。
- ◇ 粉体物料制丸。
- ◇ 中药喷雾制粒及包衣。
- ◇ 制备10-30目大颗粒冲剂。
- ◇ 粉体、颗粒、丸的薄、肠溶、缓控释包衣。
- ◇ 掩味、防潮、防氧化、防水、隔热、着色、隔离包衣。
- ◇ 粉状、粒状、团状物料干燥。
- ◇ Multi-function such as granulating, pelleting, coating in one machine.
- ◇ Powder material granulating.
- ◇ Powder material coating.
- ◇ Powder material pelleting.
- ◇ Chinese medicine spray drying, granulating and coating.
- ◇ Make 10-30 meshes big granule.
- ◇ Film coating of Powder, granules and pellets, entericrelease, slow and control release coating.
- ◇ Taste masking, odor, moisture-proof, anti-oxidation, prevent water,heat insulation,coloration and separation coating.
- ◇ Powder, granule, agglomerate material drying.



► 设备可选流化床特点 Fluid beds for choose

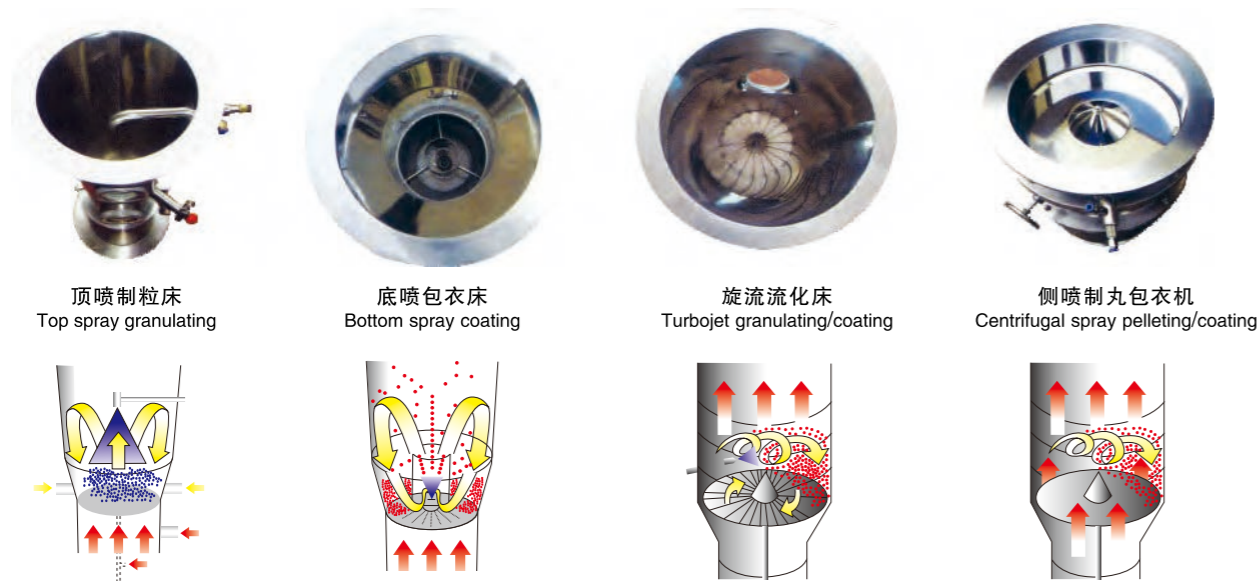

► 结构示意图 Sketch of structure

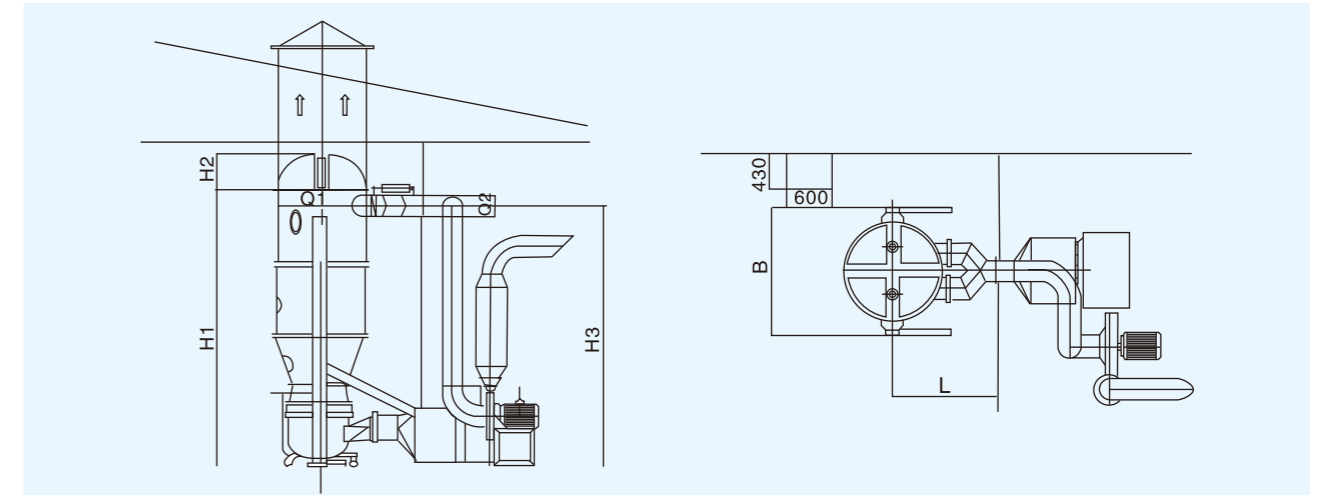

► 技术参数 Technical parameters

项目 item		机型 (FLP) Model/specifications									
名称 name	单位 unit	10	15	20	30	45	60	90	120		
容器直径 dia of container	mm	700	800	900	1000	1100	1200	1400	1500		
生产能力 productive capacity	kg/批 kg/batch	2.5-10	3-15	5-20	7.5-30	10-45	15-60	20-90	30-120		
风机功率 power of fan	kw	5.5	7.5	7.5	7.5	11	11	15	18.5		
	压强 pressure	Mpa 0.4-0.6									
蒸汽 steam	耗量 consumption	Kg/h	35	42	47	60	140	160	180	240	
压缩空气 compressed air	压强 pressure	Mpa	0.6								
	耗量 consumption	m³/min	0.6	0.6	0.6	0.9	0.9	1.1	1.3	1.5	
噪音 noise		dB	风机处理不大于75分贝 No more than 75bt separated of fan								
主机尺寸 installation size for reference	H ₁ (mm)	2790	3350	3650	3720	3720	3850	3950	4190		
	H ₂ (mm)	340	490	490	590	640	690	740	790		
	H ₃ (mm)	2570	3130	3130	3500	3500	3630	3720	3975		
	Φ ₁ (mm)	700	1000	1000	1200	1300	1400	1500	1600		
	Φ ₂ (mm)	250	250	250	280	280	280	280	315		
	L(mm)	1250	1400	1450	1500	1550	1600	1650	1700		
	B ₁ (mm)	1160	1460	1560	1600	1760	1860	1960	2060		
B ₂ (mm)	1860	2460	3460	2860	2860	3260	3460	3660			

所有数据仅供参考，视物料情况，本公司有变更权利，并不另行通知。
All dates are used for reference only. According to the condition of material our factory has the right to change but not notice, pardon.

概述 Descriptions

◇DH系列干法辊压造粒机是采用干法挤压工艺技术，对含水量<2%的粉状物进行压缩成片，再经过破碎、整粒、筛分工艺，使片状物料变成符合使用要求的颗粒状物料。

◇干法辊压造粒主要是靠外部加压方式，使物料强制通过两个反面旋转的辊轮间隙，压缩成片。在辊压过程中，物料的实际密度能增大1.5-3倍，从而达到一定的强度要求。

◇Adopts dry pressing technology to pressure material with moisture content of lower than 2% into sheets, and it's processed into required particles through breaking, granules treating and screening process.

◇The material is pressed by exterior force, and passes through the gap between the two rollers which are rotating in different directions, and then it is pressed into sheets. The mass density of material might increase 1.5-3 times, so to achieve required strength.

原理 Principle

◇各种干粉物料从设备顶部加入，经脱气、螺旋预压进入两个平等辊轮，辊轮相对旋转，物料被强制送入两辊之间，辊轮将物料咬入辊隙进行压缩，物料通过压缩区后，物料的表面张力和重力使之自然脱出。脱出后的指条状团块进入碎粒机由旋转刀排破碎，被破碎的物料进入整粒机通过滚动刀排使颗粒和部分粉状物料进入旋振筛进行筛分。合格品通过输送机被送入成品仓。粉状筛下物料通过输送机再次被送回原料仓进行二次辊压，挤压力的大小可根据造粒操作的需要由液压油缸的压力进行调节。

◇通过改变辊面开槽形式，可得到片状、条状、扁球状物料。

◇Dry material powder is fed from the top of the equipment, de-air, screw-pre-press, enter into the gap between the two rollers that are rotating in opposite directions. The pressed material falls down because of surface tension and gravity when passes through pressing section. The noddles shaped material then enters into breaking machine, been smashed by rotating knife. The smashed material enters into granulator, and then the particles and part of powder material enters into sieve by the rolling knife, and then the product is separated. The product up to standard will be conveyed to product silo by conveyor; the material under the sieve should be fed back to raw material silo and should be pressed again. The pressure might adjust by the hydraulic oil cylinder according to the requirements of granulation.

◇Sheet, bar and other shape of product might be procured by choose the relative shape of the grooves on the surface of the roller.

特点 Features

◇物料经机械压力强制压缩成型，可以不添加任何湿润剂，产品纯度得到保证。

◇干粉直接造料，无需后续干燥过程，更有利于现有生产流程的衔接和改造。

◇颗粒强度高，堆积比重的提高较其它造粒方式都更为显著。尤其适合于增加产品堆积比重的场合。

◇可控制环境污染，减少粉体浪费和包装成本，提高产品运输能力。

◇结构紧凑，维修方便，操作简单，工艺流程短，能耗低，效率高，故障率低，适合原料范围广，辊压力可根据不同物料自由调整。

◇加料和喂料装置采用变频无级调整控制，自动化程度高，可实现一人多机控制，劳动强度低及可长期连续运转等特点。

◇主要传动部件均采用优质合金材料、不锈钢材料、钛材、铬和其他表面合金制作，大大提高了耐磨损、耐腐蚀、耐高温及耐压能力，使该机具有较长的使用寿命。

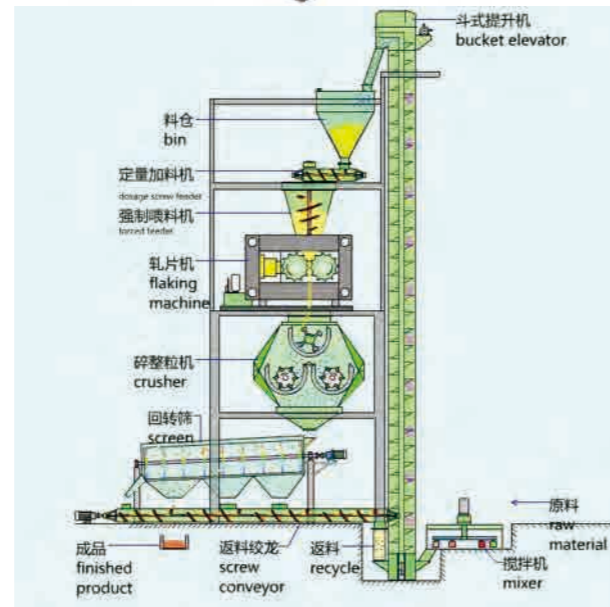

◇ The material is forced and to be pressed by mechanical force, without any additional ingredients, so to ensure purity.
 ◇ The dry material is made into granules directly, no need any further drying process. So it's good for product process.
 ◇ The strength of the particles are high, the mass density is increased more apparently compare to other method of granulation. It's especially applicable for to increase the mass density of product.
 ◇ The pollution of environment is controlled, the wasted powder is reduced, the packaging fee is decreased and the product is easier in transportation.
 ◇ The structure is compact, the maintenance is convenient, the operation is simple, the process is short, the energy consumption is low, the efficiency is high, the probability of fault is low, the application range is wide, and the pressure of roller might be adjusted freely according to the property of material.
 ◇ The material feeding adopts non-step inverter control, the automation level is high. One operation might control multi-units of machine. The labor intensity is low, and the the machine might run continuously in long time.
 ◇ Adopt high quality alloy, stainless steel, Ti, Cr and other metal for driving parts, the wear-resistance, cossive-resistance, thermo-resistance and pressure-resistance is highly increased. The service life is long.

应用 Applications

石油化工 Oil & chemical 金属粉末 Metallic power

精细化工 Fine chemical 医药 Medicine

农药 Agrochemical 化肥 Fertilizer

生物工程 Biosynthesis 食品 Foodstuff

矿产, 煤炭 Mine, Coal mine

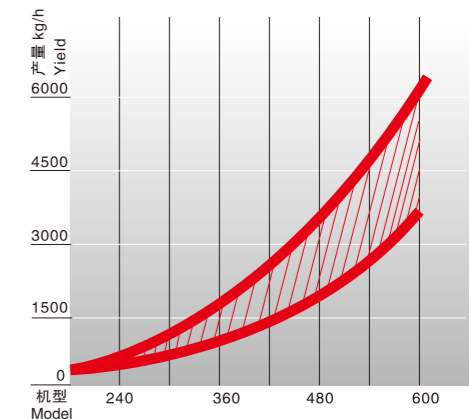
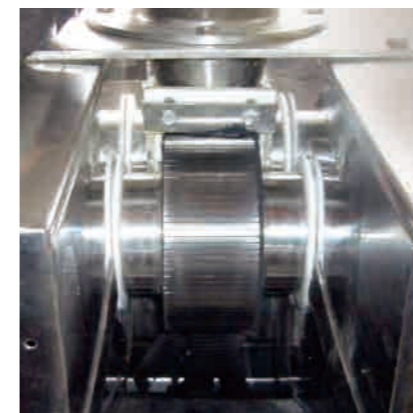

在压块时，粒状物料在两个反向旋转的辊子之间被压实，压块可使用粘结剂。
 When the press block, granular material between two counter-rotating rolls by compaction, briquetting binder can be used.

技术参数 Technical parameters

型号 model	DH-360	DH-450	DH-650	DH-850
辊轮直径 diameter of roll (mm)	Φ360	Φ450	Φ650	Φ850
辊轮有效使用宽度 width of roll (mm)	170-230	190-280	290-330	380-450
辊轮转速 revolution of roll (rpm)	10-25	10-25	10-25	10-25
最大成形压力 Max. pressure of roll (Mpa)	800	1300	2100	2900
轧片最大厚度 Max. thickness of pill (mm)	8	13	16	25
轧片产量 capacity of pill (kg/h)	1600	3000	6000	10000-16000
成品产量 capacity of finished product (kg/h)	900-1300	1800-2500	3500-4000	6000-8000
成品粒度 diameter of finished pill (mm)	0.5-6	0.5-6	0.5-6	0.5-6
主机功率 power of main machine (kw)	30-37	55-75	90-110	210-250
装机总容量 total power (kw)	55	90	175	298
外形尺寸 overall dimension (LxWxH) (mm)	2350x2000x2600	2600x2000x9000	3600x2800x3200	4200x3500x3500
设备总重量 weight (t)	10	15	25	33

概述 Descriptions

粉体物料与粘合剂在圆筒形容器中由底部混合浆充分混合成湿润软材，然后由侧置的高速粉碎桨切割成均匀的湿颗粒。

The powder raw material and adhesive in a cylinder are mixed fully at the bottom to turn into a humid soft material. Then it is crushed at a high speed and become uniform granules.

特点 Features

- ◇ 本机采用卧式圆筒构造，结构合理。
- ◇ 充气密封驱动轴，清洗时可切换成水。
- ◇ 流态化造粒，成粒近似球形，流动性好。
- ◇ 较传统工艺减少25%粘合剂，干燥时间缩短。
- ◇ 每批次干混2分钟，造粒1-4分钟，工效比传统工艺提高4-5倍。
- ◇ 在同一封闭容器内完成，干混-湿混-制粒，工艺缩减，符合GMP规格。
- ◇ 整个操作具有严格的安全保护措施。
- ◇ The machine adapts a practical horizontal cylinder structure.
- ◇ The driving shaft is equipped with inflatable seal. While washing, the air can be replaced by water.
- ◇ Fluidized granulating processed is used and the final granules are quite round with high fluidity.
- ◇ Compared with traditional technique, this type of machine can reduce 25% of adhesive and also shorten the drying time.
- ◇ For each batch of material, with 2 minutes' dry mixing and 1-4 minutes' granulating, the efficiency is 4-5 times higher than that of traditional technique.
- ◇ Dry mixing, wet mixing and granulating are finished inside the same sealed container, which is in conformity with the requirements of "GMP".
- ◇ The whole operation has strict safe and protective measures.

工艺流程 Technological process

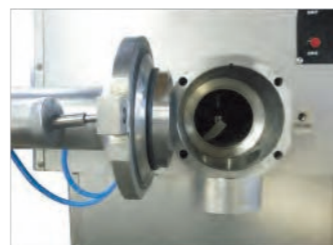
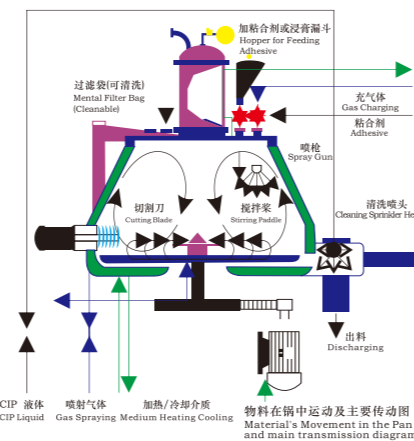
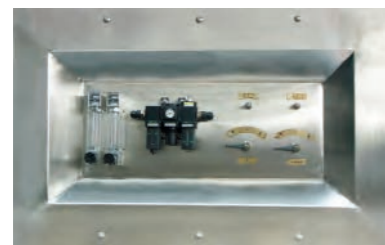
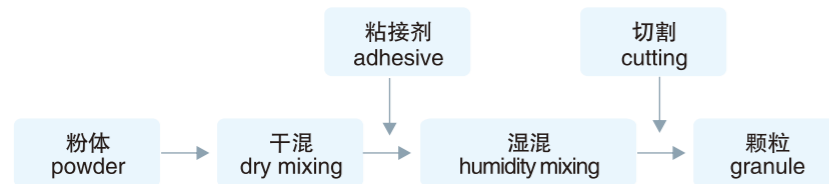

技术参数 Technical parameters

名称 Name	规格 Specification							
	10	50	150	200	250	300	400	600
容积 Capacity(L)	10	50	150	200	250	300	400	600
产量 Output(kg/batch)	3	15	50	80	100	130	200	280
混合速度 Mixing speed(r.p.m)	300/600	200/400	180/270	180/270	180/270	140/220	106/155	80/120
混合功率 Mixing power(kw)	1.5/2.2	4/5.5	6.5/8	9/11	9/11	13/16	18.5/22	22/30
切割速度 Cutting speed(r.p.m)	1500/3000	1500/3000	1500/3000	1500/3000	1500/3000	1500/3000	1500/3000	1500/3000
切割功率 Cutting power(kw)	0.85/1.1	1.3/1.8	2.4/3	4.5/5.5	4.5/5.5	4.5/5.5	6.5/8	9/11
压缩空气耗量 Amount of compressed air(m ³ /min)	0.6	0.6	0.9	0.9	0.9	1.1	1.5	1.8

平面布置图 Drawing of layout

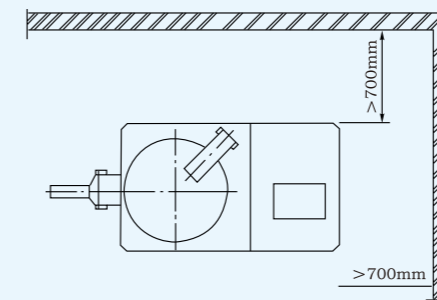

外形尺寸 Overall dimensions

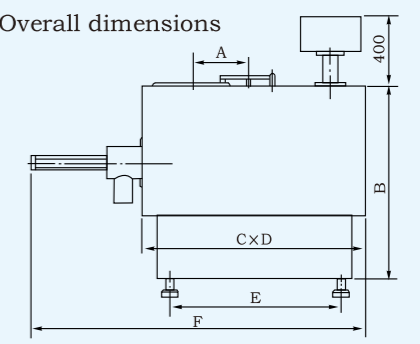

型号 Type	A	B	C x D	E	F
10	270	750	1000 x 650	745	1350
50	320	950	1250 x 800	970	1650
150	420	1000	1350 x 800	1050	1750
200	500	1100	1650 x 940	1450	2050
250	500	1160	1650 x 940	1400	2260
300	550	1200	1700 x 1000	1400	2310
400	670	1300	1860 x 1100	1550	2410
600	750	1500	2000 x 1230	1750	2610

概述 Descriptions

- ◇ 工作时发热小，粉尘少。
- ◇ 定子筛网由不锈钢板加工而成，不易损坏。
- ◇ 粉碎刀与筛网间隙可调。
- ◇ 可处理粘性，树胶状、热敏性和湿润物料。
- ◇ There is less heat and dust in work.
- ◇ The fixed screen is made from stainless steel and it can not damage easy.
- ◇ The gap between crush knives and screen can be adjusted.
- ◇ It can treat adhesive, glue, hot and wet raw materials.



应用 Applications

- ◇ 本机适用于中西药、食品、化工颜料及饲料等行业中颗粒的破碎及整理。
- ◇ 经各种造粒工艺及设备所得到的颗粒形状及规格各异。将造粒后的颗粒经本机高速旋转的刀片组合切割后，经网板排出，便可得到形状及规格基本一致的颗粒。
- ◇ 本机全部零件均采用不锈钢制造，表面抛光，装拆与清洗十分方便。
- ◇ This machine is suitable for crushing and processing granule of Chinese traditional medicine, Western medicine, foodstuff, chemicals, pigments, feedstuff and so on.
- ◇ The specifications and shapes of granule made by all kinds of granulating process and different granulator are different. The granule with basic similar shape and specification can be got when the granulated granule is cut by knives with high speed in this machine.
- ◇ All parts in this machine are made of stainless steel. Its assembling and disassembling and cleaning are very convenient.

技术参数 Technical parameters

型号 model	KZL200	KZL300
生产能力(kw)productivity	100-500	30-300
主轴转速(rpm)speed	1200,2000,2840	
功率(kw)power	1.5	
重量(mm)weight	200	260
外形尺寸(LxWxH)overall dimension	1070x900x1474	1000x380x1120

QZL系列球形抛丸机 QZL Series Shot Blasting Machine

概述 Descriptions

本机是通过设置旋转离心盘、鼓风机、气动喷枪，将湿颗粒制成美丽的球丸。将前道工序做成的湿颗粒投入旋转离心盘内，启动鼓风机后再将旋转离心盘启动，使湿颗粒受到环隙空气浮力、旋转离心力、自身重力作用，呈环周绳股状运动，从而形成真球度极高的球丸。

This machine makes damp granule into beautiful pellet by setting rotating centrifugal disk, blower, and pneumatic nozzle. Feed damp granule into rotating centrifugal disk, start fan then start rotating centrifugal disk. It can make the damp granule in float and circle by the air from gap, rotating centrifugal strength and itself gravity, appear circle rope-turning movement and become high-round pellet.



技术参数 Technical parameters

规格spec	单位unit	Φ230	Φ400	Φ500	Φ700	Φ1000	Φ1300
动力power	Kw	0.75	2.2	3	3.7	5.5	7.5
能力capacity	Kg/h	2.5-4	5-8	8-16	40-80	70-150	100-300

所有尺寸仅供参考，视物料情况，本公司有变更权利，并不另行通知。
All sizes are used for reference only. According to the condition of material our factory has the right to change but not notice, pardon.

概述 Descriptions

本机是通过一组旋转碾刀，将前道工序制成的湿材注入环碾刀的不锈钢筛筒筛孔中，从而制成圆柱状的湿颗粒，供下道工序抛丸使用。本设备可通过更换不锈钢筛筒来取得不同大小的颗粒。

制湿颗粒也可根据物料和所需球形颗粒的大小。

This machine adopts one pair of rotating grinding blade to grind form damp material into column-shape granule by stainless steel sieve cylinder which is provided to pelletize in next process.

The machine can obtain different size granule by changing the stainless steel sieve.



技术参数 Technical parameters

筒直径 Diameter of cylinder(mm)	筛筒孔径 Diameter of sieve(mm)	生产能力(kg/h) Productivity	电机功率(kw) Motor power	外形尺寸(mm) Overall dimension
250	2-2.2	100-200	4	700 x 540 x 1300
300B	1.2-3	140-400	5.5	880 x 640 x 1300
30D	0.5-6	300-600	7.5-6	1300 x 800 x 1200



所有尺寸仅供参考，视物料情况，本公司有变更权利，并不另行通知。
All sizes are used for reference only. According to the condition of material our factory has the right to change but not notice, pardon.

YK160系列摇摆式制粒机 YK160 Series Swaying Granulator

概述 Descriptions

本机适用于制药、食品、化工、固体饮料等行业的制粒，将搅拌好的物料制成所需尺寸的颗粒，或将结块状物料打成小颗粒。

The machine is suitable for pharmaceutical, foodstuff, chemical, solid drink and so on industries. It can make the stirred raw materials become granule with needed size or crush the blocked raw materials into small granule.

技术参数 Technical parameters

型号	Model A,B	Model C
生产能力 (kg/h)	100-200	150-300
电机功率 (kw)	2.2	3
滚筒转速 (r/min)	65	65
摇摆角度 (度)	360°	360°
滚筒直径 (mm)	φ 160	φ 160
外形尺寸 (mm)	1150 x 680 x 1150	1260 x 750 x 1150
重量 (kg)	300	450



应用 Applications

本机广泛用于医药, 化工, 食品, 染料, 饲料, 化肥, 农药等行业。尤其适用于大吨位(1000L-20000L)各种固相物料的混合。

本机混合筒在转动的同时又参与摆动, 使筒中物料得以充分混合, 使该机具有混合迅速, 混合量大, 出料便捷等特点。

The mixers are widely used in pharmaceutical, food, dye, feed, chemical fertilizer and pesticide industries and especially suitable for mixing various solid materials with large volume(1,000 to 12,000 litres).

The mixing barrel swings while rotates so that the materials in the barrel can be fully mixed. Because the discharge port of the barrel is out of the barrel centreline, the mixer features quick mixing and discharging, as well as high volume mixing capacity.

结构示意图 Sketch of structure

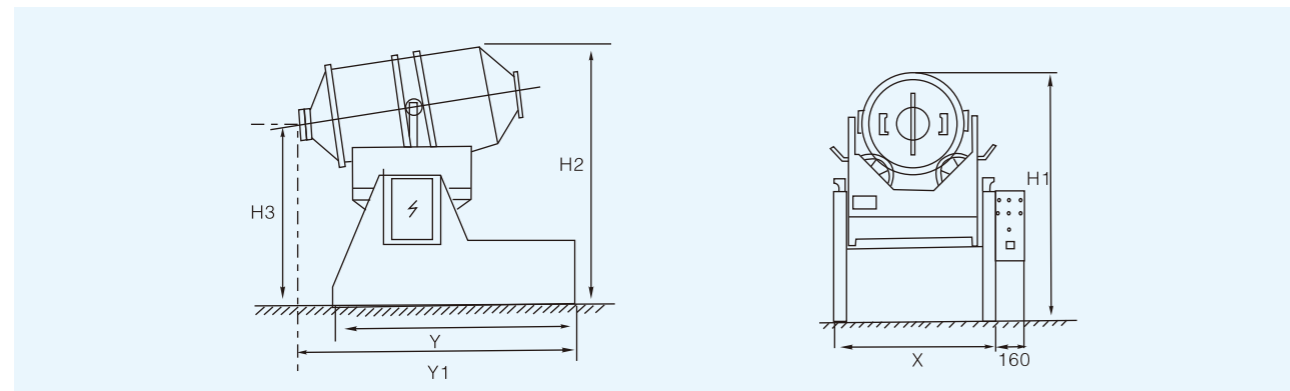

技术参数 Technical parameters

型号 Model	料筒容积 Barrel Volume (L)	最大装料容积 Max Loading capacity (L)	最大装料量 Max loading weight(Kg/批)	旋转/摇摆 (r/min)	电机总功率 Total motor Power (Kw)	外形尺寸 Overall dimensions X × Y × H3 × H2 × H1 (mm)	Y1 (mm)	筒体直径 (mm)	总重量 Total weight (Kg)	料筒重量 Barrel weight (Kg)
EYH-300	300	180	90	17.5/11	1.3	975 × 905 × 825 × 1650 × 1550	1900	600	340	60
EYH-600	600	360	180	15/9	3	1145 × 1105 × 950 × 1900 × 1750	2200	750	600	140
EYH-800A	800	480	240	11/6.4	3	1300 × 2000 × 925 × 2050 × 1850	2800	820	1200	200
EYH-1000A	1000	600	300	8/5	3	1380 × 2450 × 900 × 2050 × 1900	3050	900	1300	240
EYH-1500A	1500	900	450	8/5	4.4	1480 × 2250 × 1100 × 2350 × 2200	3300	1000	1750	320
EYH-2000A	2000	1200	600	8.3/4.7	5.2	1640 × 2630 × 1080 × 2450 × 2300	3500	1130	1900	430
EYH-3000A	3000	1800	900	6.8/3.8	8	1890 × 2750 × 1180 × 2750 × 2570	3900	1300	3500	620
EYH-4000A	4000	2400	1200	6.8/3.8	9.5	1970 × 3490 × 1230 × 2900 × 2720	4700	1400	4100	800
EYH-5000A	5000	3000	1500	6.7/3.8	9.5	2100 × 3600 × 1380 × 3200 × 3000	5000	1500	5500	900
EYH-6000A	6000	3600	1800	5.6/3	13	2240 × 3790 × 1430 × 3400 × 3150	5200	1600	6100	1100
EYH-8000A	8000	4800	2400	4.5/2.7	13	2450 × 4350 × 1700 × 3850 × 3550	5700	1800	9000	1450
EYH-10000A	10000	6000	3000	3.8/2.2	18.5	2630 × 4900 × 1630 × 4050 × 3650	6300	1900	10000	1700
EYH-12000A	12000	7200	3600	3.8/2.2	18.5	2730 × 5200 × 1800 × 4450 × 4050	6600	2020	13000	2000
EYH-15000A	15000	9000	4500	3.2/2	22	3000 × 5280 × 2020 × 4650 × 4350	6700	2300	15000	2500
EYH-20000A	20000	12000	6000	3.2/1.9	30	3250 × 5550 × 2100 × 5000 × 4650	7500	2500	18000	3100

注: 装料重量是按物料假比重0.5克/厘米3计算。Note: the loaded weight will be calculated in accordance with 0.5g/cm3 of specific gravity. 本说明内容仅供参考, 因设备更新改进较快, 敬请以最新资料为准; 特殊要求, 另行约定。



应用 Applications

◇ 该机用于制药、化工、食品、轻工、电子、机械、矿冶、国防工业以及各科研单位的粉状、颗粒状物料的高均匀度混合。

◇ 物料无离心力作用, 无比重偏析及分层、积聚现象, 各组分可有悬殊的重量比, 混合率达99.9%以上, 是目前各种混合机中的一种较理想产品。

◇ 装料率大, 最高可达80%(普通混合机仅为40%), 效率高, 混合时间短。

◇ 筒体各处为圆弧过渡, 并经过精密抛光处理, 达到GMP要求。

◇ The mixers are suitable for mixing powder and granulate materials in pharmaceutical, chemical, foodstuff, light industrial, electronic, machinery, mining, metallurgical and national defence industries, featuring high evenness mixing.

◇ Because the mixing barrel moves in multiple directions, there is no centrifugal force acting on the material, as well as no phenomena of gravity segregation, delamination and accumulation of materials so that the mixing rate can be up to 99.9 percent for the materials with big difference in terms of specific gravity. Therefore, it is an ideal product currently compared with other various mixers.

◇ The barrel has high loading rate(max. 80 percent, however, only 40 percent for the conventional mixers), so that it features high efficient and short mixing time.

◇ The barrel transitional radius everywhere, which has been super finished.

原理 Principle

装料的筒体在主动轴的带动下, 作周而复始的平移转动和翻滚等复合运动, 促使物料沿着筒体作环向、径向和轴向的三向复合运动, 从而实现多种物料的相互流动、扩散、积聚、掺杂, 达到均匀混合的目的。

Driven by the driving shaft, the barrel with the materials loaded performs cycling compound movements of translation and tumbling, which make the materials move annularly, radially and axially in the body, thus achieving mutual flow, spread, accumulation and mixing of materials for the purpose of fully mixing.

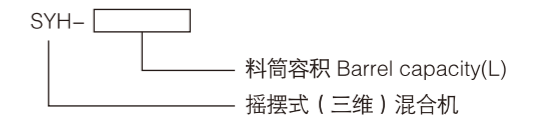

例: SYH-100表示料筒容积为100升的三维运动混合机
Example: SYH-100 means 3-Dmixer with barrel capacity of 100 litres.

技术参数 Technical parameters

型号 Model	SYH-5	SYH-10	SYH-15	SYH-20	SYH-50	SYH-100	SYH-200	SYH-400	SYH-600	SYH-800	SYH-1000	SYH-1200	SYH-1500
料斗容量 (L) Barrel capacity	5	10	15	20	50	100	200	400	600	800	1000	1200	1500
最大装料容积 (L) Max Loading capacity	4	8	12	16	40	80	160	320	480	640	800	960	1200
最大装料重量 (Kg) Max loading weight	2.5	5	7.5	10	25	50	100	200	300	400	500	600	750
电机功率 (Kw) Motor power	0.55	0.55	0.75	0.75	1.1	1.5	2.2	4	5.5	7.5	7.5	11	11
外形尺寸 (mm) Overall dimensions	深 L	720	850	900	1000	1400	1700	1800	2100	2400	2600	2650	3100
	宽 W	650	700	750	800	1000	1200	1400	1800	2200	2380	2500	2850
	高 H	950	1050	1100	1150	1200	1500	1600	1950	2350	2500	2600	2930
整机重量 (Kg) Total weight	150	180	200	250	300	500	800	1200	1500	2000	2500	3000	3500

注: 装料重量是按比重0.5克/厘米3计算。本说明内容仅供参考; 特殊要求, 另行约定。Note: the loaded weight will be calculated in accordance with 0.5g/cm3 of specific gravity.

概述 Descriptions

由螺旋的公、自转使物料在锥体内产生复合运动，主要产生四种运动形式：

1. 螺旋沿壁公转，使物料沿锥壁作圆周运动；
2. 螺旋自转使物料自锥底沿螺旋上升；
3. 螺旋的公、自转复合运动使一部分物料被吸收到螺旋圆柱面内同时受螺旋自转的离心力作用使螺旋圆柱面内的一部分物料向锥体径向排放；
4. 上升的物料受自身重力作用下降。四种运动在混合机内产生对流、剪切、扩散、从而达到快速均匀混合的目的。

The material is made to conduct a compound motion in the cone because of the rotation and revolution of the screws. The effected motions include:

1. The revolution of the screw along the wall making the material conduct a circumferential motion;
2. The rotation of the screw making the material rise along the screw from the cone bottom;
3. The compound motion of the rotation and revolution of the screws making partial material be absorbed into the screw cylindroid meanwhile, under the action of centrifugal force, the partial material in the screw cylindroid discharges radially.
4. The risen material drops under its sole weight. The four kinds of motions effect convection, shearing, diffusion in the cone, thus quick and even mixing can be achieved.

特点 Features

- ◇可加装飞刀，喷淋雾化装配，满足特殊工艺要求。
- ◇出料阀有手动、气动两种方式。
- ◇特殊物料可加大电机功率（加重型）。
- ◇This model of machine can be equipped with single screw, double screws, tri-screws.
- ◇It can be equipped with flying-entter additionally, so as to meet the requirements for special technology.
- ◇The discharge valve adopts two ways, one is manual or the other is pneumatical.
- ◇The power of motor can be enlarged for special material(strengthening type).

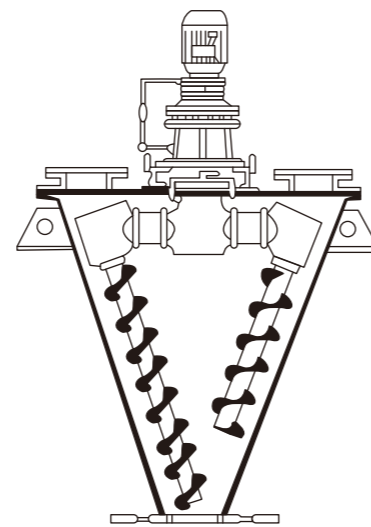

应用 Applications

应用于化工、医药、农药、染料、石油、冶金、建材等粉体与粉体(固-固)，粉体与液体(固-液)，液体与液体(液-液)混合、反应、干燥、冷却。

It is suitable for chemical industry, pharmaceutical industry pesticide, dyestuff, petroleum industry, metallurgical industry, construction material and etc. Such as in the mixing, reaction, drying, cooling of powder and powder(solid-solid), powder and liquid (solid-liquid), liquid and liquid (liquid-liquid).



技术参数 Technical parameters

型号 type	全容积 Total volume (m ³)	装载系数 Load factor	装机功率 Equipped power Kw	操作条件 Operating conditions	外形尺寸 Overall dimension(mm)	重量 Weight (kg)
DSH-0.1	0.1	≤0.6	1.5	常温常压粉尘密封	1569 φ702	250
DSH-0.3	0.3	≤0.6	2.2	常温常压粉尘密封	1929 φ920	550
DSH-0.5	0.5	≤0.6	3	常温常压粉尘密封	2322 φ1124	660
DSH-1.0	1.0	≤0.6	4	常温常压粉尘密封	2869 φ1480	1200
DSH-1.5	1.5	≤0.6	5.5	常温常压粉尘密封	3140 φ1633	1350
DSH-2.0	2.0	≤0.6	5.5	常温常压粉尘密封	3489 φ1816	1500
DSH-3.0	3.0	≤0.6	7.5	常温常压粉尘密封	3747 φ2210	2300
DSH-4.0	4.0	≤0.6	11	常温常压粉尘密封	4362 φ2280	2520
DSH-5.0	5.0	≤0.6	15	常温常压粉尘密封	4576 φ2402	3000
DSH-6.0	6.0	≤0.6	15	常温常压粉尘密封	4900 φ2582	3150
DSH-8.0	8.0	≤0.6	18.5	常温常压粉尘密封	5405 φ2805	4500
DSH-10	10	≤0.6	20.7	常温常压粉尘密封	5795 φ3018	5500
DSH-15	15	≤0.6	24.2	常温常压粉尘密封	6475 φ3450	6600
DSH-20	20	≤0.6	41	常温常压粉尘密封	7535 φ3805	7000
DSH-25	25	≤0.6	41	常温常压粉尘密封	7995 φ4078	8500
DSH-30	30	≤0.6	52.5	常温常压粉尘密封	8385 φ4330	9200

DSH系列锥形螺杆螺带混合机 DSH Series Screw Conical Mixer

概述 Descriptions

由摆线针轮减速机连接中心螺杆及外层螺带以相同转速转动。工作时，中心螺杆将混合物料由底部提升到顶部，同时线速度较大的外部螺带将物料由下而上沿锥形筒壁盘提升，二种运动在离心力作用下又将物料沿切线方向抛向空间，物料产生强烈的对流剪切、扩散，从而达到快速混合的目的。(螺杆也可做成反向螺杆)。

The central screw and the outer ribbon are connected to the cycloidal needle wheel reducer, and rotate at an identical revolution. In operation, the central screw lifts the material from bottom to top. meanwhile, the ribbon with a higher linear velocity spirals to lift the material from bottom to top along the cone wall. The two kinds of motions make the material be thrown into the space tangentially. and the material effects strong convection shearing and diffusion, thus a quick mixing effect is achieved. (the screw can also be made to a reverse one).



技术参数 Technical parameters

型号 type	全容积 Total volume (m ³)	装载系数 Load factor	装机功率 Equipped power Kw	操作条件 Operating conditions	外形尺寸 Overall dimension(mm)	重量 Weight (kg)
DSH-0.3	0.3	≤0.6	2.2	常温常压粉尘密封	1929 φ920	320
DSH-0.5	0.5	≤0.6	4	常温常压粉尘密封	2322 φ1124	410
DSH-1.0	1.0	≤0.6	7.5	常温常压粉尘密封	2869 φ1480	900
DSH-1.5	1.5	≤0.6	11	常温常压粉尘密封	3140 φ1633	1200
DSH-2.0	2.0	≤0.6	11	常温常压粉尘密封	3489 φ1900	1300

► 概述 Descriptions

本机适用于制药、化工、食品等行业两种以上干粉状、颗粒状物料的混和。

该机混和筒结构独特，混和效率高、无死角，采用不锈钢材料制作，内外壁抛光处理，外形美观，混和均匀，适用面较宽，并能根据用户的要求配套强制搅拌器，以适合较细的粉粒、块状、含有一定水份的物料混合之用。

This machine is suitable for mixing two or more dry and powder or granule raw materials from pharmaceutical industry, chemical industry, foodstuff industry and so on.

The structure of this machine is unique. Its mixing efficiency is high and no dead corner. It is made of stainless steel. Its inner and outer wall is processed through polishing. Its appearance is beauty.

Its mixing is uniform. Its scope of application is wide. The forced stirrer can also be equipped in order to meet the requirements of raw materials that contain fine powder, cake and certain moisture as request.

► 结构示意图 Sketch of structure

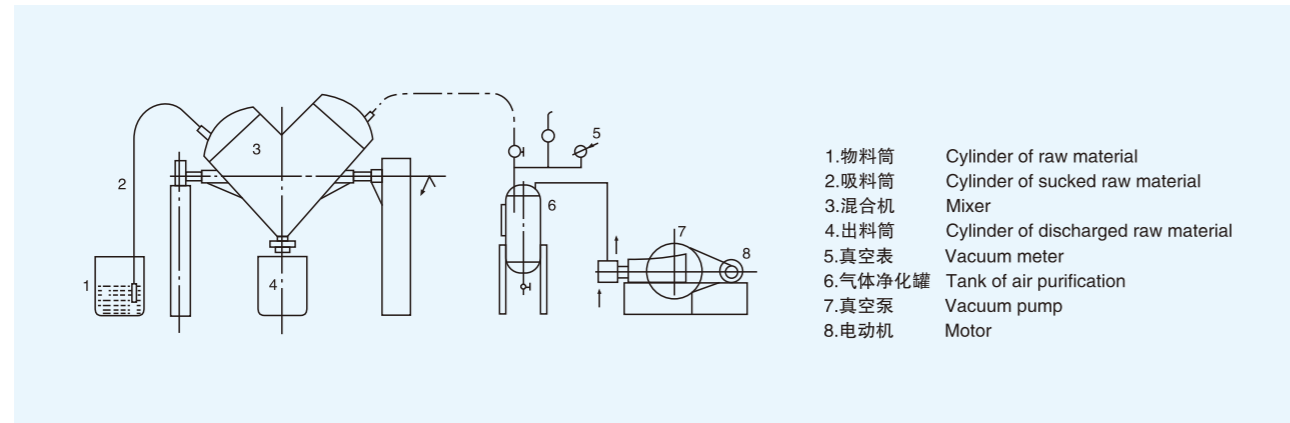

► 技术参数 Technical parameters

型号规格 Model and specification	V-0.18	V-0.3	V-0.5	V-1.0	V-1.5	V-2.0	V-2.5	V-3.0	V-4.0	V-5.0	V-6
生产能力 Productive capacity (kg/time)	72	90	150	300	450	600	800	900	1200	1500	1800
配用真空泵型号 Model of vacuum pump	W2	W2	W2	W3	W3	W3	W3	W4	W4	W4	W4
进料时间 Time of raw material fed in (min)	3-5	3-5	4-6	6-9	6-10	8-13	8-15	8-12	10-15	15-20	18-25
混合时间 Mixing time (min)	4-8	6-10	6-10	6-10	6-10	6-10	6-10	8-12	8-12	8-12	8-12
全容积 Total volume (m³)	0.18	0.3	0.5	1.0	1.5	2.0	2.5	3.0	4.0	5.0	6.0
搅拌速度 Stirring speed (r/min)	12	12	12	12	12	12	12	10	10	10	10
电机功率 Power of motor (kw)	1.1	1.1	1.5	3	4	5.5	7.5	7.5	11	15	18.5
回转高度 Rotating height (mm)	1580	2160	2360	2600	2800	2900	3000	3200	4000	4500	5000
重量 Weight (kg)	280	320	550	950	1020	1600	2040	2300	2800	3250	3850

注：装载系数：均为0.4-0.6 该表中的生产能力均安装系数0.5，物料密度0.8计算。
Notes:all loading coefficient is 0.4-0.6.the productive capacity listed in the table is calculated in accordance with 0.5 of loading coefficient and 0.8 of raw material density.

► 原理 Principle

将物料装入方锥形密闭混合桶内，料斗对称的轴线与回转轴轴线成一夹角，不同组物料在密闭的料斗中进行三维空间运动，产生强烈翻转和扩散收缩作用，达到最佳的混合效果。

The material into square taper sealed mixing barrel, hopper and rotary axis of symmetry axis into an angle, different components of the material in the hopper in a confined three-dimensional space motion, produced a strong contraction of flip and diffusion, the best mixed results.



► 特点 Features

- ◇整机设计新颖、结构紧凑、外形美观、混合均匀度达99%。体积装料系数达0.8。
- ◇回转高度低、运转平稳，性能可靠，操作方便。
- ◇桶体内外壁均经镜面抛光，无死角、易出料、易清洗，无交叉污染，符合GMP要求。
- ◇The novel design, compact structure, beautiful appearance, uniformity of 99%. volume loading coefficient was 0.8.
- ◇Low rotation height, stable operation, reliable performance, easy operation.
- ◇Both inside and outside of the barrel body are polished by mirror, no dead angle, easy to discharge, easy to clean, no cross contamination, in accordance with GMP requirements.

► 应用 Applications

FZH系列方锥型混合机是一种广泛应用于制药、化工、冶金、食品、轻工、饲料等行业的新颖物料能非常均匀地混合粉体或颗粒，使混合后的物料达到最佳效果。

FZH series square cone mixer is a novel material widely used in pharmaceutical, chemical, metallurgy, food, light industry, feed and other industries. It can mix powder or particles evenly, so that the mixed material can achieve the best effect.

► 技术参数 Technical parameters

参数 parameter	型号 type					
	FZH-300	FZH-500	FZH-1000	FZH-1500	FZH-2000	FZH-3000
混合桶容积mixing bucket volume(L)	300	500	1000	1500	2000	3000
最大装料容积Maximum loading volume(L)	240	400	800	1200	1600	2400
最大装料重量Maximum charge weight (kg)(kg)	150	250	500	750	1000	1500
主轴转速Spindle speed (RPM)(rpm)	14	13	12	10	10	8
电机功率Motor power(kW)	1.5	2.2	4	5.5	7.5	11
整机重量Machine weight(kg)	600	750	1200	1650	2000	3000
外形尺寸Dimensions(动态)	1850 × 1280	2200 × 1530	2800 × 2000	2930 × 2330	3300 × 2550	3800 × 3000
长 × 宽 × 高LxWxH(mm)	× 1980	× 2220	× 2820	× 3355	× 3280	× 3800

特点 Features

◇ 本机将粉末或粒状物料通过真空输送或人工加料到双锥容器中，随着容器的不断旋转，物料在容器中进行复杂的撞击运动，达到均匀的混合。

◇ 本机节约能源、操作方便、劳动强度低、工作效率高。

◇ Through the vacuum conveyor for the machine, send the powder or grain state materials into the double-taper container, or send the materials into the container manually.

◇ As the container rotates continuously, the materials moves complexly in the container so as to get the uniform mixing.



应用 Applications

本机适用于医药、化工、食品、建材等行业的粉状、粒状物料的混合。

It is suitable for mixing the powder and grain state materials in the pharmacy, chemical food, building material and other industries.



技术参数 Technical parameters

型号 Model	全容积 Total volume (m ³)	生产能力 Productive capacity (kg/批)	混合时间 Mixing time (min)	筒体转速 Revolution of cylinder (rpm)	功率 Power (kw)	外形尺寸 Overall dimension (mm)	回转总高度 Rotation height (mm)	重量 Weight (kg)
180	0.18	90	4-8	12	1.1	1400 × 800 × 1850	1850	280
300	0.3	150	6-10	12	1.1	1685 × 800 × 1850	1850	310
500	0.5	250	6-10	12	2.2	1910 × 800 × 1940	1950	550
1000	1.0	500	6-10	12	3	2765 × 1500 × 2370	2460	810
1500	1.5	750	6-10	10	4	2960 × 1500 × 2480	2540	980
2000	2.0	1000	6-10	7-10	5.5	3160 × 1900 × 3500	3590	1500
2500	2.5	1250	6-10	7-8	7.5	3386 × 1900 × 3560	3650	2150
3000	3.0	1500	6-10	7-8	7.5	4450 × 2200 × 3600	3700	2500
4000	4.0	2000	6-10	7-8	11	4750 × 2500 × 3680	3730	3200

概述 Descriptions

用于混合粉状或湿性物料，使不同比例主辅料混合均匀。本机与物料接触处均采用不锈钢制造，桨叶与桶身间隙小，混合无死角，搅拌轴两端设有密封装置，能防止物料外泻，料斗采用按钮点动控制，出料方便。广泛用于制药、化工、食品等行业。

Used for mixing powder or wet materials, so that main and auxiliary materials with different proportions can be mixed evenly. The contact parts of this machine with materials are all made of stainless steel, the gap between the paddle and the barrel is small, and there is no dead angle in mixing. The two ends of the stirring shaft are equipped with sealing devices to prevent the materials from leaking out, and the hopper is controlled by button inching, so that the discharging is convenient. Widely used in pharmaceutical, chemical, food and other industries.

技术参数 Technical parameters

型号 Type	容量 Volume (L)	电机功率 motor power (kw)	外形尺寸 Overall dimension (mm)	搅拌转速 stirring speed (rpm)	倒料角度 inclined angle (°)	重量 weight (kg)
150	150	3	1600 × 600 × 1100	24	105	500
200	200	4	1800 × 700 × 1200	24	105	650
500	500	7.5	2000 × 900 × 1600	24	105	850



GHJ 系列立式高速高效混合机 GHJ Series Of Vertical Speed, High Efficiency Mixer

概述 Descriptions

GHJ系列高速混合机是我公司技术人员在吸取国内外先进技术的基础上，独立研制的新型搅拌混合设备，该系列高速混合机以其精良的结构，合理的设计理念，精细的加工工艺，广泛应用于制药、食品、化工、等行业各种粉体、干湿混合物料的混合。具有混合快速均匀、操作方便，易清洗，结构紧凑、坚固耐用等优点，是新一代理想的混合设备。

GHJ series high-speed mixer is a new type of mixing equipment independently developed by our technicians on the basis of absorbing advanced technology at home and abroad. With its excellent structure, reasonable design concept and fine processing technology, this series of high-speed mixer is widely used in mixing various powders and dry and wet mixed materials in pharmaceutical, food, chemical and other industries. It has the advantages of fast and uniform mixing, convenient operation, easy cleaning, compact structure, firmness and durability, etc. It is an ideal new generation of mixing equipment.



原理 Principle

利用安装于机体底部的主桨叶高速旋转产生的离心作用力，使物料形成径向（内外）、轴向（上下）全方位的对流交错混合，安装在筒壁上的高速侧向碎料桨叶将送来的物料彻底打乱变向混合。由于二种桨叶的高速旋转及相互配合，能使物料在较短时间内达到混合均匀的目的，其混合速度和均匀度均领先于国内各种同类档次的混合机，混合均匀度非常理想。具有快速、高效、均匀度高的特点。

The centrifugal force generated by the high rotating speed of the main blade installed at the bottom of the machine body makes the materials form a radial (inside and outside) and axial (up and down) omni-directional convection staggered mixing, and the high-speed lateral crushing paddle installed on the cylinder wall completely disrupts the delivered materials and turns to mix. Due to the high-speed rotation and mutual cooperation of the two kinds of blades, the materials can be mixed evenly in a short time, and the mixing speed and uniformity are better than those of domestic mixers of the same class, and the mixing uniformity is very ideal. It is characterized by rapidity, high efficiency and high uniformity.

特点 Features

- 可配置喷雾雾化器，进行定量加液混合。加装飞刀粉碎装置，进行粉碎剪切处理。
- 可设定搅拌时间，实现计时混合。
- 加料、放料方便，半敞口上盖投料快捷方便，抽插板放料，出料快速彻底。容器内无死角易清洗。
- 设备的密封结构经过精心设计，密封性能可靠，维修拆装方便，使用寿命长。
- 适用于粉体。不同比例的干、湿物料的混合，特别适用于鸡精、各类药品、饮料冲剂等多品种、组分物料的混合。
- 标准型为整体固定式结构，也可设计成四轮直立移动式结构，方便客户灵活移动使用。

- Liquid spray atomizer can be configured for quantitative liquid mixing. A flying knife crushing device is installed for crushing and shearing.
- The mixing time can be set to realize timed mixing.
- Convenient feeding and discharging, quick and convenient feeding of the semi-open upper cover, quick and thorough discharging by the pulling and inserting plate. The container is easy to clean without dead ends.
- The sealing structure of the equipment has been carefully designed, with reliable sealing performance, convenient maintenance and disassembly and long service life.
- Suitable for mixing powder, dry and wet materials with different proportions, especially for mixing chicken essence, various medicines, beverage granules and other kinds of materials.
- The standard type is an integral fixed structure, or it can be designed as a four-wheel upright mobile structure, which is convenient for customers to move flexibly.

技术参数 Technical parameters

型号 Model	工作容量 Working capacity	搅拌重量 Mixing weight (KG/次)	装机功率 Installed power	外型尺寸 Installation dimensions (mm)
GHJ-350	350	150	7.37	1500 × 1090 × 1200
GHJ-400	400	200	8.07	1500 × 1090 × 1300
GHJ-850	850	400	10.87	1718 × 1320 × 1400

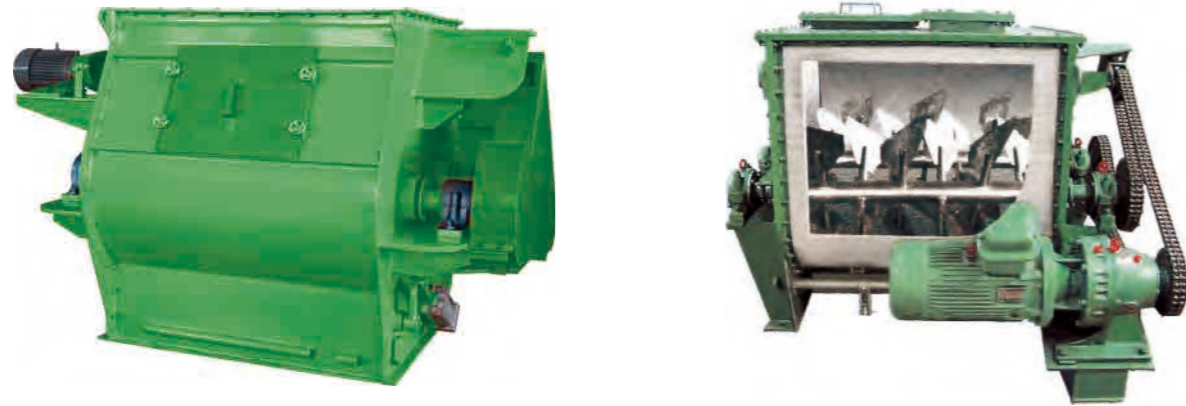

▶ 原理 Principle

本系列混合机以强烈、高效混合为特点、卧式筒体内两根搅拌等速反向旋转，轴上特殊布置的桨叶确保物料径向、环向、轴向三向运动，形成复合循环，在极短的时间内达到均匀混合。

This series machine takes a strong and high effective mixing as its features the two mixing axes rotate reversely at an identical revolution in the horizontal drum body. The paddles, specially distributed on the axle ensure that the material move radically, circulatingly, and axially, so as to form a compound motion, and in an extremely short time, the material is mixed evenly.

▶ 特点 Features

- ◇混合精度高，速度快，能耗低，可密封操作。
- ◇气动、电动、手动出料方式
- ◇筒盖上可布置雾化装置以实现固液混合
- ◇The equipment can run in an enclosure, with high precision, high speed, low energy consumption.
- ◇Pneumatical, electrical and manual discharging method.
- ◇The atomizing device can be distributed on the cylinder cover to realize the solid-liquid mixing.

▶ 应用 Applications

化学药品、洗涤剂、涂料、树脂、玻璃硅、颜料、农药、化肥、饲料、饲料添加剂、小麦粉、奶粉、香料、微量成分、咖啡、食盐、砵添加剂、塑料及各种浆料、粉料的干燥与混合。

It is suitable for the drying and mixing of the following materials: chemicals, detergent, fertilizer, feedstuff, feedstuff additive wheat flour, milk power, perfume, micro ingredient, coffee, gourmet power, salt, plastic and all kinds of pulp, power material.

▶ 技术参数 Technical parameters

型号规格 model & specs(m ³)	WZ-0.05	WZ-0.1	WZ-0.3	WZ-0.5	WZ-1	WZ-2	WZ-3	WZ-4	WZ-6
一次混合 mixed amount/batch(kg)	24~30	40~60	120~180	200~300	400~600	800~1200	1200~1800	1600~2400	2400~3600
装机功率 equipped power(kW)	2.2	3	4~5.5	5.5~7.5	7.5~15	15~18.5	18.5~22	22~30	30~37
设备重量 weight(kg)	250	360	750	880	2100	2740	3800	5100	6600

注：以上产品材质分碳钢C、不锈钢P。
Note: The above-mentioned products can be made in carbonaceous steel C or stainless steel P.

▶ 原理 Principle

该机型由容器、螺旋搅拌叶片和传动部件组成；螺旋叶片一般做成双层或三层，外层螺旋将物料从两侧向中央汇集，内层螺旋将物料从中央向两侧输送，形成对流混合。容积可做成圆形，以便夹套用于反应、干燥。

This machine is composed of container, screw stirring paddles and transitional parts; the screw paddle are generally made into 1 layer or 3 layers, the outer screw converge is the material to the centre front two sides, and the inner layer of screw conveys the material to the two sides from the centre, so as to form convection mixing. The cubage can be made into rotundity, so the jacket can be played in reaction and drying.

▶ 特点 Features

装载系数大、设备占地面积小。
Big coefficient of loading, small occupied area.

▶ 技术参数 Technical parameters

型号规格 Model & Specs m ³	WLDH-0.1	WLDH-0.3	WLDH-0.5	WLDH-1	WLDH-1.5	WLDH-2	WLDH-3	WLDH-4	WLDH-6	WLDH-8	WLDH-10
一次混合 Mixed amount/batch Kg	30-50	100-150	200-300	400-600	600-900	800-1200	1200-1800	1600-2400	2400-3600	3200-4800	4000-6000
装机功率 Equipped power Kw	1.5-4	3-5.5	4-11	7.5-15	11-18.5	15-22	18.5-30	22-37	37-55	37-55	45-75
设备重量 Dead Weight Kg	420	850	1060	1790	1900	2750	3500	4280	5300	6800	7800

上述产品按客户要求由A₃钢或不锈钢制造。
The above-mentioned products can be made in A₃ steel or stainless steel acc. To customer's requirements.



LDH系列犁刀混合机 LDH Series Coulter Mixing Machine

▶ 概述 Descriptions

该机型由传动机构、卧式筒体、犁刀、飞刀四部分组成；物料在犁刀作用下沿筒壁作轴向流动，当物料流经飞刀时被高速旋转的飞刀抛洒，从而在较短时间内达到均匀混合。

This machine is composed of transmission apparatus, horizontal cylinder, colter flying cutter; under the action of colter, the material conducts a turbulent flow circumferentially along the cylinder wall, and the materials is thrown and sprinkled by the rotating flying-cutter at a high speed when it flows through the flying cutter, thus the material is mixed evenly in a shorter time.

▶ 技术参数 Technical parameters

型号规格 Model & Specs(m ³)	LDH-0.1	LDH-0.3	LDH-0.5	LDH-1	LDH-2	LDH-4	LDH-6	LDH-8	LDH-10	LDH-12	LDH-15
一次混合 Mixed amount/batch(kg)	40-60	120-180	200-300	400-600	800-1200	1600-2400	2400-3600	3200-4800	4000-6000	4800-7200	6000-9000
装机功率 Equipped power(kw)	6	8.4	9.9	23	30.5	38	38	46	53	65	82.5
设备重量 Dead Weight(kg)	430	950	1100	1800	2520	3220	6750	7200	7500	8500	9200

上述产品按客户要求由A₃钢或不锈钢制造。
The above-mentioned products can be made in A₃ steel or stainless steel acc. To customer's requirements.

▶ 特点 Features

- ◇混合时间短、对粒度、密度差异大的物料混合有较好的适应性。
- ◇结构特点特别适合加液混合和造湿粒，粒径在0.3-3mm之间。
- ◇ The mixing time is short. It has a better adaptability to the mixing of the materials, which has large differences in size and specific gravity.
- ◇ Its construction feature is that it is especially suitable for liquid adding mixing or granulating wet particle, the size is between 0.3-3mm.



30B系列高效粉碎机 (机组)

30B Series High Effect Grinder Machine(Set)

粉碎系列 GRINDING SERIES

干燥 制粒 混合 粉碎 辅助

概述 Descriptions

本机(组)适用于医药、化工、食品、农药等行业脆性物料的粉碎，用途极为广泛。

This machine(set) is extensively used in pharmaceutical, chemical food and pesticide industries for pulverizing dry brittle materials.



技术参数 Technical parameters

型号 Model	20B/20B机组(set)	30B/30B机组(set)	40B/40B机组(set)	60B/60B机组(set)
生产能力 Productive capacity (kg/h)	60~150	100~300	160~800	500~1500
主轴转速 Revolution of main shaft (r/min)	4500	3800	3400	2800
进料粒度 Size of fed material (mm)	6	10	12	15
粉碎细度(目) Grinding size (mesh)	2-120	2-120	2-120	2-120
电机功率 Power of Motor (kw)	4	5.5	7.5	15
吸尘风机功率 Fan power	0.75	0.75	1.1	2.2
重量 Weight (kg)	250	320	550	680

注：因物料差异及要求目数不同，表中产量仅供参考。
Notes: the outputs in list are only for reference, due to the difference of material and the wanted sizes.

WF-30B中草药粉碎机 WF-30B China Herb High Speed Grinder

应用 Applications

该机具有技术性能稳定、产量高、外形美观。适用范围广等特点。本机对于粉碎干燥纤维性物料具有较理想的效果。与国内其他机型相比，制品温度低，粒度均匀，特别适用于食糖、塑料粉末、中药等热敏性物料的粉碎。

The machine has stable technical performance, high production capacity and beautiful appearance. It has large application. It can get very ideal result to pulverize the drying fibre material. It is suitable for heat sensitivity materials such as sugar, plastic powder and Chinese traditional medicine.



技术参数 Technical parameters

型号 (model)	30B
主轴转速 (main shaft speed)	5300转/分 (rpm)
主机电机功率 (main motor power)	7.5千瓦 (kw)
关风机电机功率 (closing fan motor power)	0.37千瓦 (kw)
引风机电机功率 (draught fan motor power)	1.1千瓦 (kw)
进料粒度 (feed grain degree)	10-40mm
粉碎细度 (pulverizing fineness)	60-220目 (任意可调) - (eye will) 常规使用
粉碎能力 (pulverizing capacity)	50-250公斤/小时 (kg/h)
主机温升 (main engine temperature rising)	≤65℃ (degree)

粉碎系列 GRINDING SERIES

先进技术 完善工艺 放心产品

C系列万能粉碎机

C Series Universal Grinder

原理 Principle

本粉碎机组由粉碎机，ESC物料收集箱和ESC吸尘器组成。解决物料在粉碎过程中粉尘飞扬。

本机的工作原理是物料进入粉碎室，在高速旋转的活动齿盘与固定齿盘间受齿的冲击、剪切、磨擦及物料间的相互撞击的作用下被粉碎，经筛网筛选后即成为所需的粉料。

本粉碎机组的粉碎机、物料收集箱和吸尘器，全部采用不锈钢材料制作。符合药品生产的“GMP”的要求。

The grinder set consists of Model 30B grinder, EXC collector of raw material and ESC collective duster. It solves the problem, i. e. The dust is flying during the period of crushing raw material.

The principle of work is as follows: after raw material is fed into the crushing chamber, it undertakes the comprehensive actions such as impacted by teeth, shearing force, friction, impacted between raw materials, finally the raw materials are crushed through sieving. The needed powder can be got.

The grinder, collector of raw material and ESC collective duster are all made of stainless steel and are in conformity with the requirements of GMP.



技术参数 Technical parameters

型号 Model	20B-C	30B-C	40B-C	60B-C
生产能力 Productive capacity (kg/h)	60~150	100~300	160~800	500~1500
主轴转速 Revolution of main shaft (r.p.m)	4500	3800	3400	2800
最大进料粒度 Max size of raw material to be fed (mm)	6	10	12	15
成品细度 Degree of fineness of finished product (目)	60-120	60-120	60-120	60-120
电机功率 Power of Motor (kw)	4	5.5	11	15
吸尘风机 Fan power(kw)	1.5	1.5	1.5	2.2
外形尺寸 Overall dimension(L×W×H)(mm)	1100×600×1650	1200×650×1650	1350×700×1700	1550×1000×1750

CSJ粗粉碎机 CSJ Series Date And Efficient Coarse Grinder

应用 Applications

本机适用于制药、化工、冶金、食品、建筑等行业。对坚硬难粉碎的物料进行加工，包括对塑料、铜丝、中草药橡胶等进行粉碎，也能作为微粉碎机、超微粉碎机加工前道工序的配套设备。

This machine is suitable for many industries such as pharmaceutical industry, chemical industry, metallurgy industry, foodstuff industry, architecture industry and so on to crush hard raw materials including plastics, steel wire, Chinese herbal medicine, rubber and so on. It can also be as complete equipment of micro fine grinder and super fine grinder as the first procedure.

特点 Features

该机是采用立式粉碎机构，不受物料粘度、硬度、软度等的限制，对任何物料都能起到粉碎作用。

This machine adapts vertical crushing mechanism. It can not be limited by viscosity, hardness and softness of raw materials. It has good crushing effect to all kinds of raw materials.

技术参数 Technical parameters

型号 type	进料粒度 (mm) inlet material diameter	出料颗粒 (mm) output diameter	产量 (kg/h) output	功率 (kw) power	主轴转速 (rpm) speed of shaft	外型尺寸 (mm) overall dimension
CSJ-40	≤100	0.5-20	50-300	5.5	940	780x800x1300
CSJ-80	≤100	0.5-20	80-800	18.5	1000	1200x1100x1700



原理 Principle

本机属于高速运转机械，采用二快口刀刃，使被粉碎物料经高速刀片剪切获得粉碎。该机还可根据不同物料选用各种形状及尺寸不同的刀片，粒度大小可通过更换网布或调正速度获得。

It is high speed revolving machine, it uses double sharp blades, it cuts so fast that the materials in the chamber is well pulverized by the revolving blades to meet the different. Various kind of blades with different shape and size can be applied, the screen meshes can be substituted to get the right granules or adjust the speed.

应用 Applications

本机采用混合喷粉法原理设计研制而成，广泛适用于制药、食品、化工等行业的粉碎。

The machine is designed according to the theory of mixing spraying power. It is widely used in the pulverizing materials in pharmaceutical foodstuff and chemical industries.

技术参数 Technical parameters

规格型号 Specification and model	GFS-8型	GFS-16型	GFS-28型
生产能力 Productive capacity(kg/h)	10~100	20~300	100~500
成品细度(目) Fineless of product(mesh)	12~20	12~120	12~120
功率 Power (kw)	3	7.5	11
可调转速 Adjustable revolution speed(r/min)	4000	4000	4000
外型尺寸 Overall dimensions (L×W×H)(mm)	800×550×1250	900×660×1350	1000×750×1665
重量 Weight(kg)	150	150	320



WFJ系列粉碎机 WFJ Series Fine Grinder

概述 Descriptions

该系列微粉碎机由主机、辅机、电控三个部分组成，设计紧凑，结构合理，具有风选式，无筛无网。机内装有分级机构，能使粉碎，分级一次完成。负压输送使粉碎作业时机腔内产生的热量源源不断地排出，故也适用于热敏性物料的粉碎。本机适应范围广，生产过程连续进行，出料粒度可调；能处理如：化学制品、食品、药品、化妆品、染料、树脂、壳物等多种物料的粉碎及分级。

Model WFJ series fine grinder consists of three parts i.e. main machine, auxiliary machine and electric control. Its features are compact in design, reasonable in structure. Its principle is using air to chose and no sieve or screen. Being installed grading mechanism inside the machine, the crushing and grading can be finished at the same time. When use negative pressure to transport in the operation of crushing, the heat produced from the chamber will be removed continuously. Therefore it can also be suitable for crushing thermal sensitive raw materials. The scope of application of machine is wide. Its productive process is continuous and its size of granule can be adjusted. It can crush and grade many raw materials such as chemicals, foodstuff, medicines, cosmetic, dyestuff, resin, shell materials and so on.



技术参数 Technical parameters

规格型号 Specification and model	WFJ-15	WFJ-18	WFJ-36
生产能力 Productive capacity(kg/h)	10~200	20~450	60~1000
进料粒径 Size of raw material to be fed(mm)	<10	<12	<15
出料粒度(目) Size of raw material to be discharged (mesh)	80~320	80~450	80~450
总功率 Total power (kw)	13.5	17.5	38
主转速 Main revolution(r/min)	4500	4480	4000
外型尺寸 Overall dimensions (L×W×H)(mm)	4200×1200×2800	4700×1250×2900	9000×1500×3800

注：1. 以上表中参数因物料差异较大，故产量和出料细度差异亦较大。

2. 脉冲除尘器用空压机由用户自备。

Notes: 1. The parameters listed in above table have more difference with difference with different raw materials, therefore the output and size of raw material to be discharged have difference too.

2. The air compressor used for pulse bag duster should be prepared by customer.

特点 Features

本机上部采用快拆手柄，把整机连成一个整体，上盖全密封、有效防止物料在过筛时由于振动而产生粉尘飞扬。筛体下部安装振动电机，有效保证了物料的结构紧凑，下部采用弹簧减振，使整机在平稳状态下工作。下面底座采用可调式，可调节正在过筛时的筛面倾斜角度，根据物料特性以取得最佳过筛效果。

It adapts quick disassembling handle at the upper part of this machine. The handle connects the machine as the whole one. Its upper cover is seal fully. Therefore it prevent from the dust flying caused by vibration during the period of sieving. The vibration motor is installed under the sieve. Mean while it adapts spring to reduce vibration. So the machine will operate at stable state. The stand is adjustable, so the inclined angel of sieve that is sieving can be adjusted. The best sieving effect can be got.



技术参数 Technical parameters

型号规格 Model and specifications	功率 Power (kw)	筛面倾斜 Inclined angle of sieve surface	电压 Voltage (v)	筛面层数 Layers of sieve surface	过筛目数(目) (Mesh)	外形尺寸 Overall dimension (mm)	重量 Weight (kg)	产量 Output (kg/h)
FS0.6×1.5	0.4×2	0°~45° 可调 0°~45° adjustable	380	1~4	6~120	1500×700×700	550	150~1500
FS0.65×2.0	0.4×2	0°~45° 可调 0°~45° adjustable	380	1~4	6~120	2100×750×780	650	160~2000

注：表中产量因物料比重目数差异其产量仅供参考。

Notes: The output listed in the table is for reference only because of the difference of the specific gravity and mesh.

ZS系列圆形振动筛 ZS Series Vibrating Sieve

原理 Principle

◇ ZS系列圆形振动筛适用于流水作业，是大小颗粒比例不等过筛连续出料的理想设备。

◇ 本机由料斗、振荡室、联轴器、电机组成。振荡室内有偏心轮、橡胶软垫、主轴、轴承等组成。可调节的偏心重锤经马达驱动传达到主轴中心线，在不平衡状态下，产生离心力，使物料强度改变在筛内形成轨道旋涡。重锤调节器的振幅大小可根据不同物料和筛网进行调整。

◇ 整机结构紧密、体积小、不扬尘、噪音低、质量高、能耗低、移动、维修方便。



◇ ZS series vibration sieve is suitable for in line production. It is an ideal device for granule that has uneven size to sieve continuously.

◇ The machine consists of hopper, vibration chamber and coupling and motor. There are eccentric wheel, rubber soft parts, main shaft bearing and so on. The adjustable eccentric weight can drive to the central line of main shaft through motor. Under the unstable state, it produces centrifugal force that makes raw material form vortex in the sieve. The size of amplitude of eccentric weight can be regulated in accordance with the different raw materials.

◇ The whole structure of machine is compact, small in volume, no dust, low in noise, low in energy consume, convenient in moving and maintenance.

技术参数 Technical parameters

型号 Model	生产能力 Production capacity (kg/h)	过筛目数(目) (Mesh)	电动功率 Power of motor (kw)	主轴转速 Revolution of main shaft (r/min)	外形尺寸(毫米) Overall dimensions (mm)	净重 Net weight (kg)
ZS-350	60~500	12~200	0.55	1380	540×540×1060	100
ZS-515	100~1300	12~200	0.75	1370	710×710×1290	180
ZS-650	180~2000	12~200	1.50	1370	880×880×1350	250
ZS-800	250~3500	5~325	1.50	1500	900×900×1200	300

应用 Applications

该炉为通用性热风装置，与各种物料的干燥设备配套使用。广泛用于粮食、种子、饲料、果品、脱水蔬菜、香菇、木耳、银耳、茶叶、烟叶等农产品、食品、医药品、化工原料、轻重工业产品的加热除湿，还可用于各种设施的加热以及库房除湿等。

The furnace is the versatile hot air equipment. It is used with other equipment for drying various materials. The furnace is widely used for the heating and moisture removing for the grain, seed, feed, fruit, de-watering vegetable, mushroom, edible fungus, tremella, tea, tobacco leaf, other farming products, food, medicine, chemical raw material, light and heavy industry products.

原理 Principle

该炉集燃烧与换热为一体以炉体高温部位进行换热的最新间接加热技术，烟和空气各行其道，加热绝对无污染，热效率高达(60-75%)，升温快，体积小，安装方便，使用可靠，且价格低(与一吨锅炉相比，该加热系统只相当于锅炉加热系统价格的一半)。

The furnace combines the combustion with the heat exchange, using the latest indirect heating technology that the heat exchange is taken place at the position of the high temperature in the furnace. The smoke and the air go into the different channels, without any pollution for the heating. The heat efficiency rate is high (up to 60-75%). The temperature increase is fast. The furnace is small in size, easy in the installation, reliable in the operation and low in the price (making a comparison with one ton boiler, the price of this system is only half price of the heating system for the boiler).



技术参数 Technical parameters

型号规格 type	技术参数 technical parameter heat output	输出热量 air output × 10 ⁴ kcal/h	输出风量 hot air temperature (m ³ /h)	热风温度 coal consumption smoke and air(°C)	耗煤量 leading blower blower for(kg/h)	烟气引风机型号 cocking blower for cocking
JRF4-2.5		2.5-3	1500-560	60-200	10-12	炊事用鼓风机 80-100W
JRF4-4		4-5	3500-930	60-200	14-17	炊事用鼓风机 200-300W
JRF5-8		6-8	5600-1480	60-200	18-24	炊事用鼓风机 350-550W
JRF5-15		10-15	12000-2160	60-300	40-45	Y5-47 4C 2000rpm 2.2Kw
JRF5-30		25-30	25000-4330	60-300	80-90	Y5-47 4C 2520rpm 3Kw
JRF6-60		55-60	45000-8660	60-300	150-175	Y5-47 4C 2900rpm 4Kw
JRF6-100		80-100	84000-1400	60-300	220-290	Y5-47 5C 2900rpm 7.5Kw
JRF6-160		150-160	134400-23000	60-300	410-460	Y5-47 6C 26200rpm 15Kw

注:

- 1、环境基准温度标准按18°C ± 2°C。煤的热值以5500kcal/kg计算。
- 2、表中热风温度是按输出风量确定的。热风输出温度高于300°C时，热风炉内壁采用不锈钢等耐高温材料制作，价格另议。
- 3、设备外形布置图来函备案。

Note:

1. The environmental datum temperature standard takes 18 ± 2°C. The thermal value for the coal takes 5500kcal/kg for the calculation.
2. The hot air temperature in the table is decided according to the air output. When the temperature is more than 300°C, the internal will be made from stainless steel, but its price is different.
3. The layout of equipment will be provided as request.

概述 Descriptions

我厂自行设计制造的 RLY 系列卧式金属体燃油间接加热热风炉是集燃烧与换热为一体，热效率高的热风加热装置（热效率可达70%-80%）。输出的热风温度可达300°C，特殊设计可达500°C-800°C。烟气和空气各走其道，故经换热后的空气为洁净的热空气。能与各种干燥设备配套使用。广泛用于粮食、种子饲料、果品、脱水蔬菜、香菇、木耳、银耳、茶叶、烟叶等农产品和医药药品、化工原料等产品的加热除湿。

Model RLY series horizontal metallic case oil fuel indirect fuel hot air furnace integrates combustion and heat exchange in its one body and is a hot air heating device with high thermal efficiency (its thermal efficiency will be 65% - 85%). The output temperature of hot air will be 300°C. If design specially, it can be 500°C-800°C. Smoke and air has its own pass. The air through heat exchange is clean hot one. It can be equipped with different drying equipment. It is wide used for heating and damp removing of agricultural, medical and chemical products such as grain, seeds, feedstuffs, fruits, dehydrated vegetables, Panania fungus, agaric, white fungus, tea, tobacco leaf, foodstuff, medicines, chemical raw materials.

特点 Features

- ◇ 操作方便，劳动强度低。
- ◇ 设备结构紧凑，占地面积小。
- ◇ 采用进口燃烧器，燃烧完全，无环境污染。
- ◇ Convenient in operation and low in labor strength.
- ◇ The equipment is compact and covers small area.
- ◇ Being adapted imported combust or, its combustion is full and no environment pollution.



技术参数 Technical parameters

型号 Type	燃烧器型号 Combustion device type	燃油量 Oil combustion (kg/h)	供热量 Heat supply capacity (10 ⁴ kcal/h)	外形尺寸 Overall dimension L × W × H (mm)	热风口 Hot air hole L × W (mm)	总重 Total weight (kg)
RLY10	Y1	13 ~ 16	10	2100 × 1300 × 1600	180 × 200	1970
RLY20	YL3	26 ~ 32	20	2800 × 1400 × 1700	200 × 250	2260
RLY30	YL3	39 ~ 48	30	3400 × 1500 × 1800	250 × 300	3160
RLY40	YL3	52 ~ 46	40	4020 × 1700 × 1900	300 × 400	4750
RLY60	YL7	78 ~ 96	60	4800 × 1900 × 2100	400 × 500	5650
RLY100	YL8	130 ~ 160	100	5400 × 2100 × 2300	550 × 650	6550
RLY200	YB10	260 ~ 320	200	6000 × 2500 × 2400	750 × 900	7980
RLY360	YB11	468 ~ 720	360	7200 × 2900 × 2600	900 × 1200	9860

概述 Descriptions

MC-II 方形脉冲布袋除尘器是在MC-I型的基础上经改进修改而成的,它除了具有I型除尘效率高、处理风量大、性能稳定、操作维修方便等特点外,还具有比I型使用效果好、不易积粉、应用范围广等特点,广泛适用于粮食食品、饲料、冶金化工、建材、医药等行业的通风除尘和粉尘回收。

On the basis of MC-II type, the square type pulsed dust filter with cloth bag MC-I is the amended and improved one. In addition to the advantages that type is high in the dust removing efficiency, big in the air capacity, stable in the performance, easy in operation and maintenance, MC-II has the better result than MC-I. Such as: it is not easy to build up the powder and its application is wide and so on. The device is widely used for the ventilation, dust removing and powder restoration in the grain, food, feed, metallurgical, chemical, building material, medical and other industries.



结构示意图 Sketch of structure

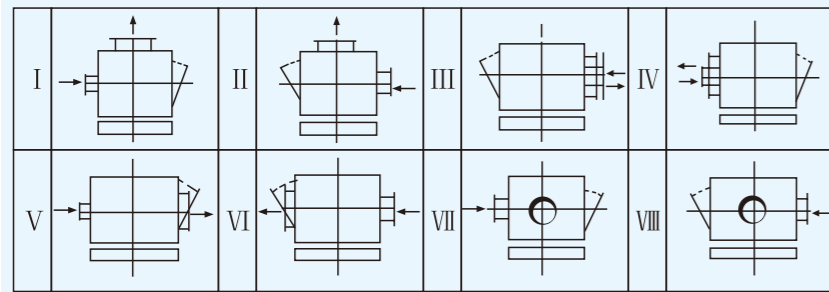

型号说明 Model specification

BLM-FII-72-II

安装形式 Way of installation
滤袋数量 Quantity of filtering bag
方形双斗 Square double hopper
脉冲布袋除尘器 Plus Cloth cyclinder duster

技术参数 Technical parameters

参数Parameter	型号Type	BLM24	BLM36	BLM48	BLM60	BLM72	BLM84	BLM96	BLM120
过滤面积Filtering area(m ²)		18	27	36	45	54	63	72	90
滤袋数量(只)Filtering bag number(piece)		24	36	48	60	72	84	96	120
过滤风速Filtering air speed(m/min)		2~4	2~4	2~4	2~4	2~4	2~4	2~4	2~4
过滤风量 Filtering air volume(m ³ /h)		2160-4300	3250-6480	4320-8630	5400-10800	6450-12900	7550-15100	8650-17300	10800-20800
最大外形尺寸(mm) Max.Overall dimension	长 Long	1000	1400	1800	2200	2600	3000	3560	4360
	宽×高 Wide×high	1450×3660							
清灰装置 Dust remover	脉冲阀数量 Pulse valve number	4	6	8	10	12	14	16	20
	耗用压缩空气量 Compressed air consumption m ³	0.07~0.30	0.11~0.40	0.15~0.50	0.18~0.60	0.22~0.60	0.25~0.90	0.29~0.90	0.37~0.90
	压缩空气压力 Compressed air pressure kg/cm ²	3~6							

概述 Descriptions

ZSL-III 系列真空上料机是我公司最新开发研制的第三代新型真空上料机,它具有上料速度快、使用周期长、操作方便、清洁卫生,符合GMP要求。

Model ZSIII serial vacuum feeder is a third-generation new-type vacuum feeder recently developed by our company. it has advantages of fast feeding, long service period, simple operation, clean and in conformity with GMP requirement.



应用 Applications

- ◇ 用于粉状、小颗粒状(φ<5mm)及球状物料。
- ◇ 用于二维、三维、双锥、V型等各种密闭容器和设备的上料。
- ◇ Used for powder, small grain and ball materials with diameter less than 5mm.
- ◇ Used for materials feeding for various kinds of sealed containers and equipments such as two-dimension, three-dimension, double-cone, V-shaped etc.



特点 Features

- ◇ 上料速度快。
- ◇ 连续工作时间长。
- ◇ 无泄漏现象,清洁卫生,适合于洁净厂房。
- ◇ 结构紧凑、移动方便、操作简单。
- ◇ 装有快装卡箍,便于拆装和清洗,符合要求。
- ◇ Fast feeding of materials.
- ◇ Long time for continuous working.
- ◇ No leakage, clean and healthy, suitable for clean workshop.
- ◇ Compact size, easy moving and simple operation.
- ◇ Equipped with fast-feeding clamping and facilitating assembling, disassembling and cleaning and in conformity with the requirement.

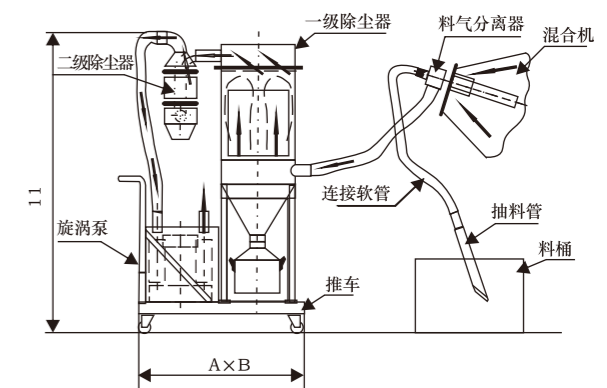

技术参数 Technical parameters

参数 Data	型号 Model	ZSL-III-2.2	ZSL-III-3.0	ZSL-III-4.0	ZSL-III-5.5	ZSL-III-7.5
工作压力 Working Pressure(kpa)		<18	<20	<22	<28	<31
风量 Air Volume(m ³ /h)		210	300	330	370	480
功率 Power(kw)		2.2	3.0	4.0	5.5	7.5
输送能力 Transporting Capacity(kg/h)		900-1200	1200-1500	1500-1800	1800-2100	2100-2400

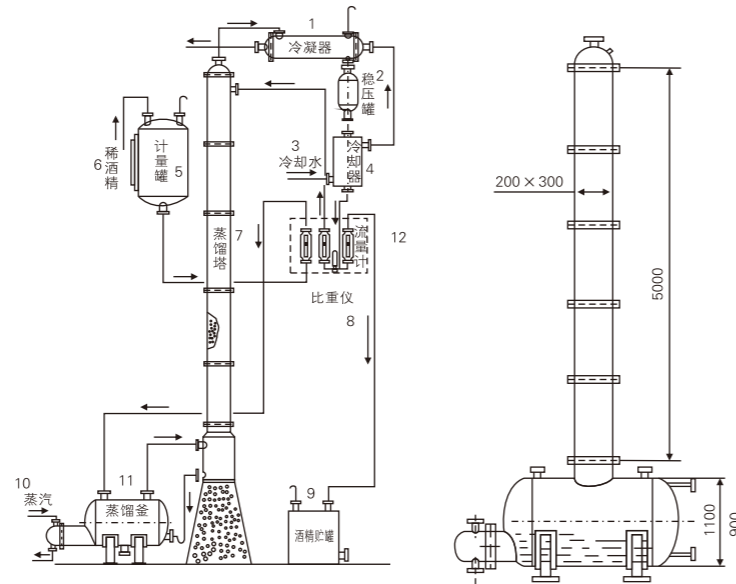

概述 Descriptions

1.酒精回收塔有塔釜、塔身、冷凝器、冷却器、缓冲罐、高位贮罐六个部分组成，适用于制药、食品、轻工、化工等行业的稀酒精回收，本设备与物料接触部分均采用OCr18Ni9不锈钢制造，具有良好的耐腐蚀性能，并且有节能、环保、降低生产成本、提高效率的优点。本装置可将30度-50度的稀酒精蒸馏到90-93度，残液排放含醇度低，符合环保要求。
2.本装置采用高效不锈钢波纹填料。接触物料部分采用不锈钢制作符合GMP标准。

1. Alcohol regenerating Tower is made of six parts including: tower bottom, tower body, condenser, cooler, buffer tank and high-order holder, which is fit for the thin alcohol regeneration from pharmacy, food stuff, light industry, chemical and other industries. The parts contact with material of the equipment are all manufactured using OCr18Ni9 stainless steel, which has good corrosion stability as well as characters like energy-saving, environment-friendly, low-cost, high-efficient. The equipment can distill thin alcohol with the concentration of 30-50 degree to 90-93 degree, whose residue discharge is at low alcohol content, which confirms to environmental protection requirements.
2. The equipment adopts high-efficiency stainless steel ripple packing, the parts contact with material are manufactured using stainless steel manufacturing which confirms to GMP standard.

技术参数 Technical parameters

规格/型号	JH200	JH300	JH400	JH500	JH600	JH800
塔釜容积 (L)	1000	1500	2000	2500	2500	3000
塔身高度 (mm)	6000	7000	7000	7000	7500	7500
高位罐容积 (L)	1000	1000	2000	2000	2000	2000
冷凝面积 (m ²)	5	9	11	18	25	45
冷却面积 (m ²)	1	1.5	2.2	4	6	8
换热面积 (m ²)	3.0	6	6.5	10	15	26
回收能力 (Kg/h)	45~50	90~110	180~220	190~310	430~450	750~780
回收浓度 (%)	≥90					
填料形式	不锈钢波纹网填料					
设备重量 (Kg)	1500	2200	3500	4000	4500	6800
外形尺寸(L×W×H)(mm)	2300×700×7300	2600×800×7500	2500×1000×9000	3000×1200×9000	3500×1400×10000	4200×1800×10000

客户选型反馈表
Feedback Form of Customers for Model Selection

请您按表格详细填写，以便本公司提供慎重的选型推荐
Please fill the form in detail so that our company can provide discreet recommended model:

单位 Unit: _____ 客户姓名 Name of customer: _____ 职务 post: _____

地址 Add: _____ 联系电话 Tel: _____ 传真 Fax: _____

E-MAIL: _____ 联系时间 Date: _____

1. 物料名称: _____
Material name:

2. 干燥物料的形态: _____
Shape of raw material to be dried: 微粉 Micro powder 粉料 Powder 颗粒 Granule 块状 Block 片状 Flake 纤维状 Fibric form
 滤饼 Filter cake 糊状 Mushy 膏状 Paste 液体 Liquid

3. 干燥物料的初含水 _____ %; 产品终含水 _____ %; Ph值 _____ ,
Primary moisture of raw material to be dried Final moisture of finished product PH value
熔点 _____ °C, 物料最高承受温度 _____ °C, 物料松散程度 _____
MP Max.withstood T of raw material Bulk density of raw material

4. 湿份主要成份: _____
Main ingredient of damp powder:

5. 水份存在的形式: 表面水 Surface water 结晶水 Crystal water
Existed form of moisture:

6. 成品细度 _____ mm (目) 湿品堆比重 _____ Kg/m³ 产品堆比重 _____ Kg/m³
Fineness of finished product Mesh Bulk specific gravity of damp product Bulk specific gravity of finished product

7. 物料有关其他特性:
Reletive other characteristics of raw materials:
 粘性 Viscosity 热敏性 Thermal sensitive 软化点 Softening point 相变点 Transition point 腐蚀性 (PH值) Causticity(PHVALUE) 异味 Peculiar smell 可燃性 Inflammability
 易爆性 Explosion hazard 静电性 Electric static 透气性 Gas permeability 团聚性 Constipate 晶体或颗粒折医粉碎性 Comminuted of crystal or granule

8. 干燥产量要求: 湿品 _____ Kg/h或干品 _____ Kg/h
Requirement of output: Damp product or dried finished product;

9. 颗粒产品能否破坏: 能 不能
Whether the granule can ben damaged: Yes No

10. 物料过去的干燥方法或类似产品的干燥方法: _____
The original dry method of raw material or dry method of similar products:

11. 干燥方式要求: 连续干燥 间隙干燥
Requirements of drying method: Continuous drying Drying in batch

12. 可供的热源: 电、 蒸汽、 热水、 导热油、 燃气炉、 燃煤炉、 燃油炉;
Heat source to de wupplied Electricity Steam Hot water Heat conduction Gas fuel furnace Coal fuel fuenace Oil fuel fernace

13. 选购设备要求制作材质: _____
Required material for manufacturing equipment when selection:

14. 环保要求及对物料回收率的要求: _____
Requirements of environmental protection and requirements of yield:

15. 可供安装场地: _____
Field to be installed:

16. 其他要求: _____
Other requirements: